

ORPHEUS | F

Broad-Bandwidth Hybrid Optical Parametric Amplifier

FEATURES

- Combination of best OPA and NOPA features
- 650 – 900 nm and 1200 – 2500 nm tuning range
- Single-shot – 2 MHz repetition rate
- < 100 fs pulse duration
- Adjustable spectral bandwidth
- Long pulse mode for gap-free tunability



ORPHEUS-F is a hybrid optical parametric amplifier (OPA), combining the short pulse duration produced by a non-collinear OPA (NOPA) and the wide tuning range offered by a collinear OPA.

The Signal pulses of ORPHEUS-F are tunable in a 650 – 900 nm range and can be compressed with a simple prism-based compressor down to 25 – 70 fs pulse duration. The Idler pulses are tunable in a 1200 – 2500 nm range and reach

pulse duration of 40 – 100 fs. In addition, a long-pulse mode is available for accessing the 900 – 1200 nm tuning range; thus, enabling a gap-free tunability.

ORPHEUS-F provides significantly shorter pulses compared to the standard ORPHEUS model and a wider tuning range compared to the non-collinear ORPHEUS-N. Thus, for many scientific applications, ORPHEUS-F is the optimal choice.

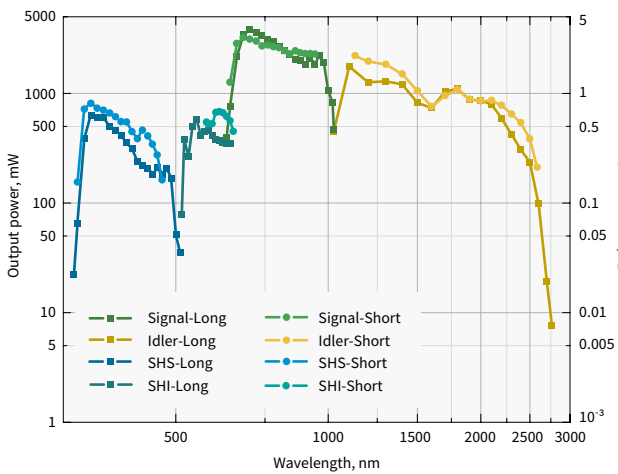

Typical tuning curves of **ORPHEUS-F**.
 Pump: 40 W, 40 μJ, 1000 kHz

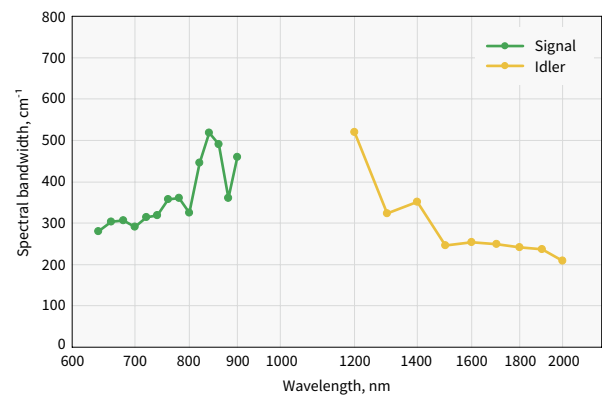

Typical spectral bandwidth of ORPHEUS-F

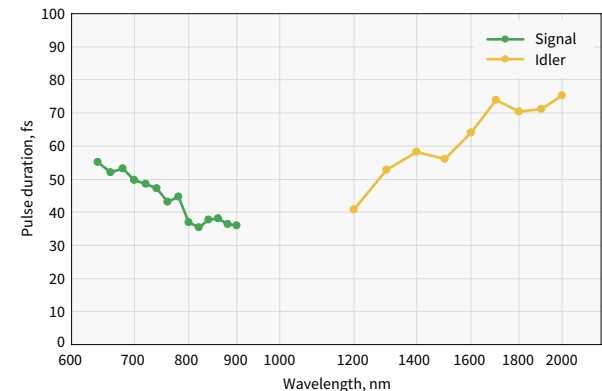

Pulse duration after compression of ORPHEUS-F

For custom tuning curves visit
<http://toolbox.lightcon.com/tools/tuningcurves/>

SPECIFICATIONS

Model	ORPHEUS-F	
MAIN OUTPUT (650 – 900 nm and 1200 – 2500 nm)		
Mode of operation	Short pulse mode ¹⁾	Long pulse mode
Tuning range	650 – 900 nm (Signal) 1200 – 2500 nm (Idler)	650 – 1010 nm (Signal) 1050 – 2500 nm (Idler)
Maximum pump power	80 W	
Pump pulse energy	10 – 500 μ J	
Conversion efficiency at peak ²⁾	> 10% (Signal and Idler combined)	
Integrated 2H (515 nm) generation efficiency ³⁾	> 35%	
Pulse duration before compression ¹⁾	< 290 fs	
Spectral bandwidth	200 – 750 cm^{-1} @ 650 – 900 nm	75 – 220 cm^{-1} @ 650 – 900 nm
Pulse duration after compressor ¹⁾	< 55 fs @ 800 – 900 nm < 70 fs @ 650 – 800 nm < 100 fs @ 1200 – 2000 nm	n/a
Compressor transmission	> 65% @ 650 – 900 nm > 80% @ 1200 – 2000 nm	
Long-term power stability, 8h ⁴⁾	< 2% @ 800 nm	
Pulse-to-pulse energy stability, 1 min ⁴⁾	< 2% @ 800 nm	

WAVELENGTH EXTENSION OPTIONS (325 – 15000 nm) ⁵⁾

325 – 450 nm (SHS)	> 1%	n/a
325 – 505 nm (SHS)	n/a	> 1%
525 – 650 nm (SHI)		> 0.5%
600 – 650 nm (SHI)	> 0.5%	n/a
210 – 252 nm (FHS)	n/a	> 0.1%
263 – 325 nm (FHI)		> 0.1%
2500 – 15000 nm	See ORPHEUS-MIR (page 38)	

¹⁾ In short pulse mode, broadband pulses are compressed externally. Typical pulse duration before compression: 120 – 250 fs, after compression: 25 – 70 fs @ 650 – 900 nm, 40 – 100 fs @ 1200 – 2000 nm.

²⁾ Specified as percentage of pump power.

³⁾ At designated output port; not simultaneous to OPA output.

⁴⁾ Expressed as NRMSD (normalized root mean squared deviation).

⁵⁾ For > 15 μ J pump pulse energy.

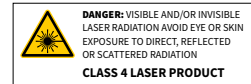

DRAWINGS

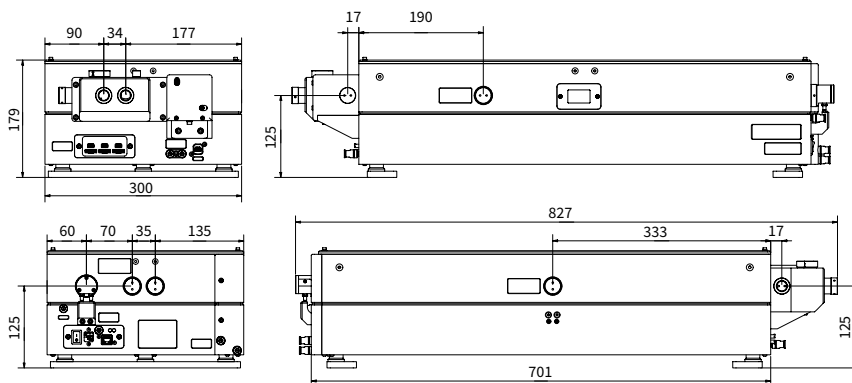

ORPHEUS-F drawings

www.gmp.ch

GMP SA
GMP SA

Main office: Avenue des Baumettes 17
Büro Zürich: Dübendorfstrasse 11a

CH-1020 Renens
CH-8117 Fällanden

Tél. 021 633 21 21
Tel. 044 825 34 00

Fax. 021 633 21 29
Fax. 044 825 34 01

info@gmp.ch
info@gmp.ch