

**GMP**

**General Microtechnology & Photonics**  
Systems for Industry, Research, Telecom & Medicine

# *µM* NANOMOTION

A Johnson Electric Company

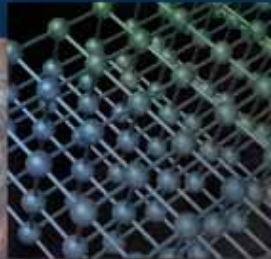

2011

[www.gmp.ch](http://www.gmp.ch)

GMP SA Siège principale: Avenue des Baumettes 17  
GMP SA Succursale de Zürich: Dübendorfstrasse 11a

CH-1020 Renens +41 21 633 21 21  
CH-8117 Fällanden +41 44 825 34 00

Fax. +41 21 633 21 29 [info@gmp.ch](mailto:info@gmp.ch)  
Fax. +41 44 825 34 01 [info@gmp.ch](mailto:info@gmp.ch)



Based on the principles of ultrasonic standing waves in piezoelectricity, Nanomotion introduces its most advanced series of electronic motors, operating similarly to DC servo motors with the high resolution and dynamic performance of piezo actuators.

## Nanomotion... *A Breakthrough Technology*

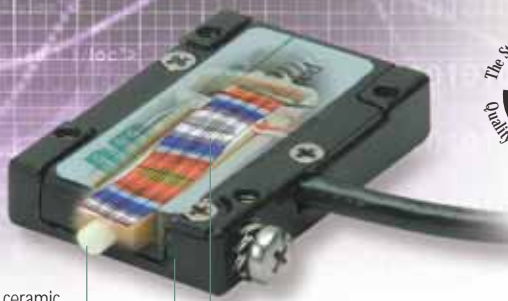

By pressing the ceramic finger tip against a ceramic strip a driving force is exerted on a linear or rotary stage, creating motion.

When the driving voltage is not applied, the compression of the finger tip to the ceramic maintains holding torque on the motion device. Unlike other braking devices, there is no position shift or hysteresis in the Nanomotion motor.

The simultaneous excitation of the longitudinal extension and transverse bending modes creates two dimensional acoustic waves resulting in a small elliptical path at the finger tip.

As the leading manufacturer of piezo-electric motors for precision motion control applications, Nanomotion's product line ranges from single element motors for actuation, to larger motors for driving typical stages. Nanomotion motors operate with no intrinsic magnetic fields and no moving parts. The motors provide unlimited travel in a compact package, with the ability to achieve unmatched precision for linear or rotary motion.

Nanomotion's motors have been successfully applied in diverse applications, from using our standard housed motors for motion control positioning in industrial automation to simply applying a piezoelectric element embedded in consumer products. Regardless of the packaging, Nanomotion brings a unique drive solution to any motion requirement.

### Table of Contents

Motor Technology	1	Ceramics	15	Amplifiers	25
Biomedical Applications	2-3	Stage Introduction	16 - 17	Amplifiers AB1A	26
Security Applications	4-5	FB Series FB050	18	Amplifiers AB2	27
Semiconductor Applications	6-7	FB Series FB075	19	Amplifiers AB4	28
HR Series	8-9	FB Series FB100	20	Amplifiers AB5	29
LS Series	10 - 11	FB Series FB150	21	Flex DC	30
ST Motor	12	FB Series FBR60 Rotary	22	Design & Technical Guide	31 - 36
Edge Motor	13	Wedge Stage FBZ075-10	23	Ordering Guide	IBC
Edge Motor Driver	14	FGB Series Geniometer	24		

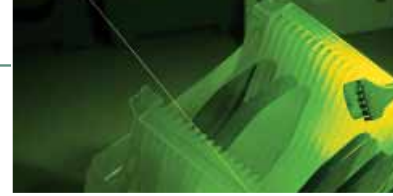

# Nanomotion's unique motor & stage technology makes it well suited to applications in:

## Medical Instruments and Devices:

- Microscopy
- Chromatography
- Analytical Instrumentation
- Focus Modules for Endoscopes
- Efficient Pump Drives

## Security:

- Shutter and Aperture Control
- Auto Focus Mechanisms
- Image Stabilization

## Semiconductor:

- Photo Lithography Process
- Wafer Inspection
- Thin Film Measurement Tools
- Scanning Electron & Ion Beam Microscopes
- Atomic Force Microscopes

An exceptionally small operating package provides unlimited travel in a convenient and easy to mount package.



CE Compliant amplifier accepts +/- 10V from most all servo controls.

Plug-N-Play with simple connectorization and easy installation.

Built-in spring cam allows for set up in less than 5 minutes, without the need for extensive alignment.

Precision crossed roller bearing stages with integral linear encoders provide a wide range of travel and performance levels.

The operating nature of the finger tips provide unprecedented move and settle capability, along with built in braking.

Step resolutions better than 20 nanometers with a wide range of velocity from 1 $\mu$ /sec to 250mm/sec.

Alumina running surface mounts to most standard slide mechanisms and is easily applied with double sided tape.



Nanomotion motors and FB stages are available in a wide range of configurations and are compatible with all standard servo controls.

## Nanomotion Motors, Stages and Modules For The BioMedical Markets

### Non-magnetic Motors:

- MRI Applications

### Standard Motors:

- Microscope Stages
- Auto Focus Axes
- High Throughput Screening
- Clean Room Assembly Applications

### Vacuum Motors:

- Laser & Mass Spectrometer Applications

### Precision Stages for Bio and Pharma Markets:

- Linear Stages for Auto Focus In Cell Analysis
- Linear and Rotary Stages for Sample Manipulation

## Medical Instruments & Device Applications

Microscope and Chromatograph applications benefit greatly from the size and motion performance that Nanomotion systems offer. Compact, open frame stages provide for thru-stage light transmission with the ability to incorporate a back light.

The ability to manage a variable amount of slides improves throughput and handling. Stages with positioning resolution from 10nm to 100nm offer rapid move and settle capability beyond that of conventional drives. Imaging on-the-fly applications benefit from the ability to achieve exceptional velocity control at different speeds.



Z Axis Auto Focus stages optimize the ability for rapid step-repeat operation for maintaining focus to follow Cell Terrain.

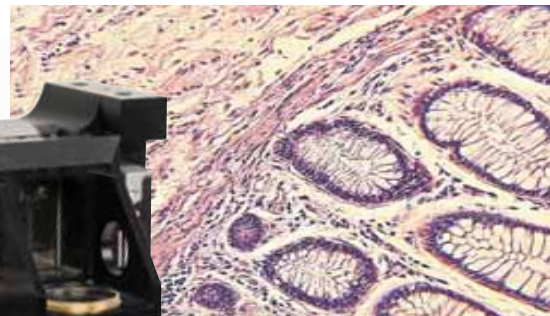

## Proteomics and Drug Development

High speed multi-axis systems use Nanomotion ceramic servo motors to provide the utmost in speed and performance, while maintaining an exceptionally small machine footprint.

Whether controlling the position of the dispensing head or actuating a series of syringes, Nanomotion provides compact, light weight motors that can operate in a lab environment.





## Non-Magnetic Motors for MRI

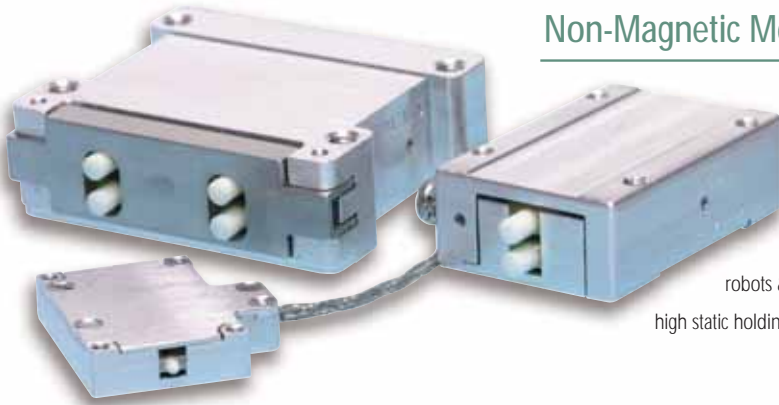

Nanomotion's – N motors are suitable to operation in a 1.5T to 3T MRI environment. These motors have no magnetic materials and no intrinsic magnetic field. Non-magnetic motors are supported by MRI compatible amplifiers that can be tuned to specific MRI frequencies to eliminate artifacts during imaging. MRI robots & manipulators use –N motors to position while the MRI is on, yielding high static holding and no power consumption at rest.

Nanomotion has configured 'traditional' rotary motors, based on its ultrasonic piezo technology to offer a common mounting, with motor shaft. These motors, ranging from 15mm OD to 70mm OD can be configured for a wide range of speed and torque requirements in standard and non-magnetic configurations.

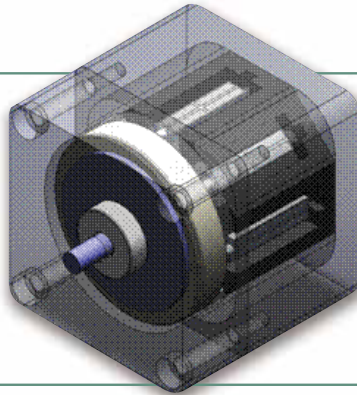

## Modules

Miniature modules, utilizing Nanomotion's Edge motor and ASIC building blocks are ideally suited to auto focus devices adapted to endoscopes and a wide variety of surgical tools. Low voltage motors can provide motion at the tip of an endoscope, functioning in a 3.6mm diameter, to provide exceptional image quality as well as tool manipulation.

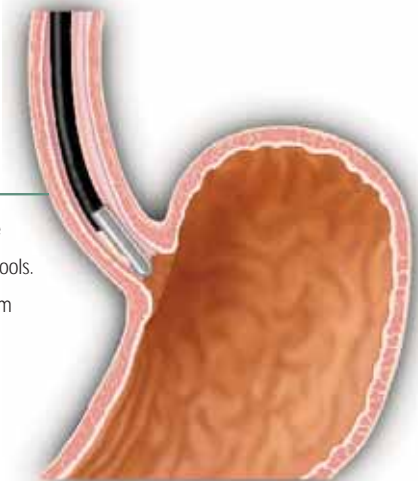

# Nanomotion Motors and Modules For the Security Market

## Standard Motors:

- Shutter & Aperture Control
- Auto Focus & Zoom
- Optical Image Stabilization

## Modules:

- Edge Actuator
- NUC Shutters
- Pan & Tilt Gimbals

## Test Data for Security Market:

- Wide Operating Temperature  
-40°C to 70°C
- Thermal Shock Test Data
- Operation Under Vibration
- Impact Shock Testing

## Shutter & Aperture Control

Nanomotion's low voltage motors are particularly well suited flight and battery operated devices in the Security Markets. Non-Uniformity Correction (NUC) Shutters and Variable Apertures benefit from the Edge motor, weighing 0.55g and supported by an ASIC that can operate at wide temperature ranges.

Low voltage motors are supported by a 5mm square ASIC that serves as a dual axis motor drive and control. The ASIC can be configured into a custom electronics to meet specific application requirements.

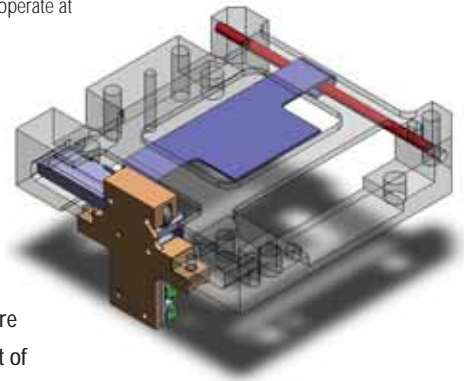

Nanomotion's high speed shutters can operate open loop, between limit switches or closed loop with a miniature position sensor. Shutters are configured with a total weight of less than 10g and a moving mass of 1.5g, with move times at 100msec or less.

Nanomotion's low voltage motors are ideal for flight and battery operated devices.

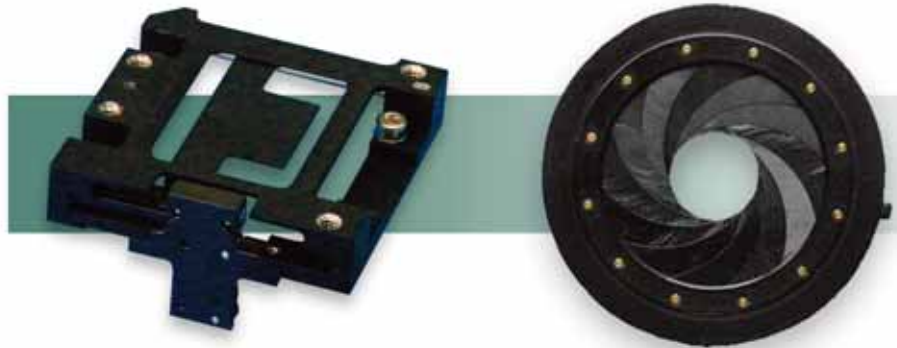



## Optical Image Stabilization

Pan and tilt mechanisms for camera control and image stabilization in cameras, binoculars and other optical devices benefit from rapid response of Nanomotion's ultrasonic standing wave motor technology.

Stabilizing a binocular can be achieved with a small pan and tilt mechanism that moves a roof prism inside an eye piece.

The Nanomotion advantage is in the ability to miniaturize such a device with exceptional low mass and stabilize both high frequency/low amplitude and low frequency/high amplitude motions.

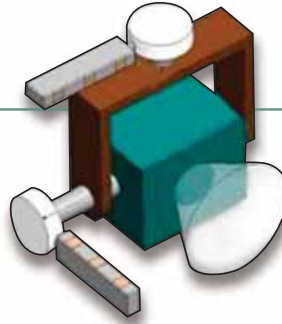
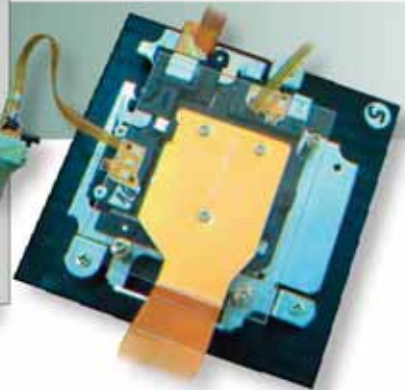
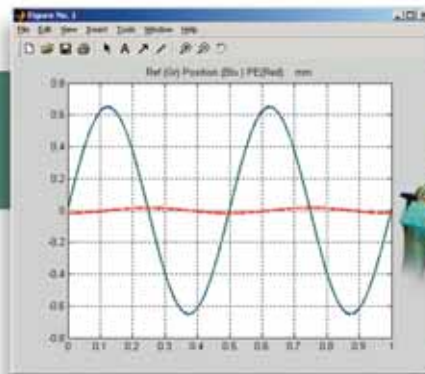

Image stabilization in camera can be achieved by shifting the image sensor in two axes, based on the input of a gyro. This allows for small rapid movements to stabilize image acquisition in a camera.

Shown to the right, the stabilization of the red line, with a disturbance of 2Hz, at an amplitude of 0.65mm.



## Nanotion Motors and FB Stages For The Semiconductor Market



### Standard Motors:

- Clean Room Applications

### Vacuum and Non-Magnetic Motors:

- E-Beam and Ion Beam Applications

### Vacuum Compatible Motors:

- High Vacuum and UHV Applications

### Standard and Vacuum Compatible FB Stages:

- Precision Linear and Rotary Stages for Clean Room and Vacuum Environments
- Custom Stage Designs for Open Frame and Small Footprints
- Well-suited To Use in E-Beam and Ion Beam Chambers

## XYZT UHV Stage for Laser / Ion Beam Micromachining of Semicon Devices



This 4 axis motion system provides XYZ and Theta motion for laser or Ion Beam machining of semiconductor chips or MEMs devices.

The stage construction is UHV compatible to 10-10 Torr and has non-magnetic motors.

Each linear axis uses 50nm resolution linear encoders and the theta axis positions to 1 arc second. This stage can operate up to 200mm/sec.

Nanotion manufactures a wide variety of vacuum and UHV motors for Semiconductor applications. Our vacuum motors, for environments up to 10-7 Torr are also available in non-magnetic configurations. These motors have no magnetic materials and no intrinsic magnetic field, and are ideal for E-Beam and Ion Beam applications, where magnetic motion can disturb the direction of the beam. Nanotion's UHV motors are inherently non-magnetic and compatible to 10-10 Torr.

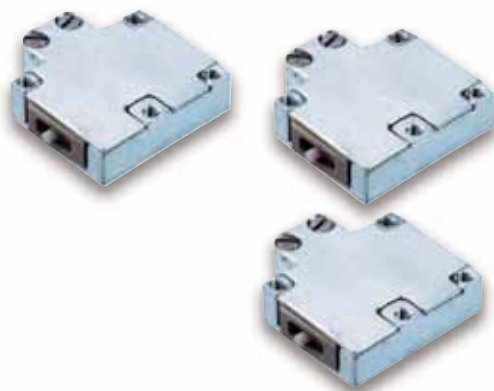
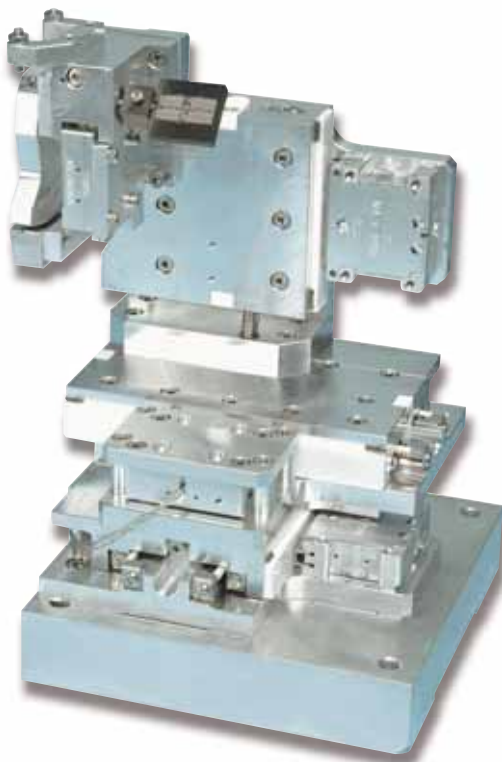



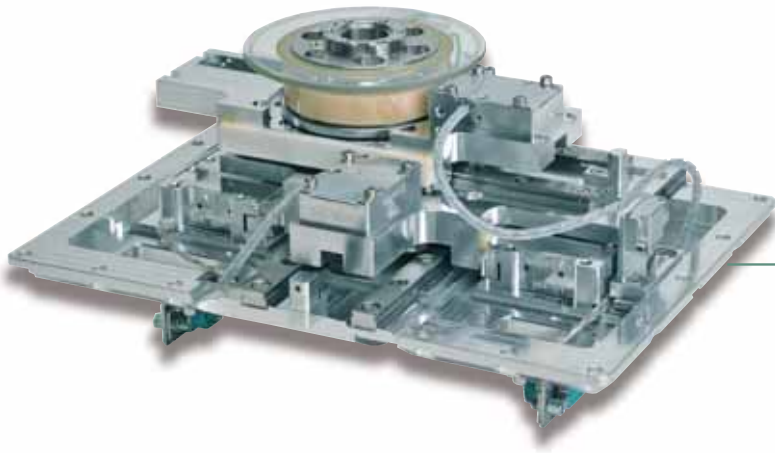

## High Vacuum Multi Axis Stage

An XY-Theta stage providing 55mm travel in X and Y at 20nm resolution and a continuous rotary axis operating at 3 arc second resolution provides high performance motion and position stability in Ion beam microscopy.

## Wafer Metrology Stage

XYZ stage provides travel to position 300mm wafers for inspection process. The XY stage provides travel of 360mm x 480mm with a vertical Z Wedge stage providing up to 25mm travel. Z stage can support a wafer chuck and position sample relative to the process tool. Stages can operate from 10nm to 100nm position resolution.

Wafer Metrology Stage providing Z-XY-Theta motion. A 25mm Z Wedge stage carries XY and Theta for small area inspection of semiconductor materials. Stages can operate from 10nm to 100nm position resolution.

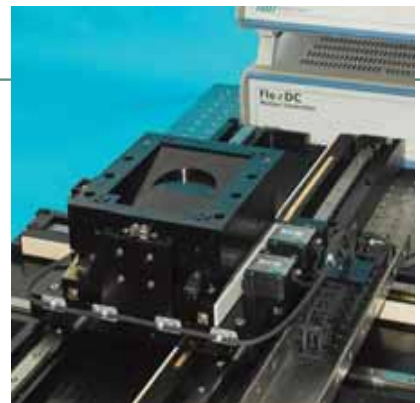

Nanomotion's HR Series motors range in size from a single element (providing 0.4kg of force) to an eight element motor (providing 3.2kg of force). The HR series is capable of driving both linear and rotary stages. The HR series motors have a wide dynamic range of speed, from several microns per second to 250mm/sec and can easily mount to traditional low friction stages or other devices. The unique operating characteristics of the HR Series motors provide inherent braking and the ability to eliminate servo dither when in a static position.

## Features

- Unlimited travel
- Wide dynamic velocity range— from 1 $\mu$ /sec to 250mm/sec
- Excellent move & settle
- Step resolutions to 10nm
- No intrinsic magnetic field
- No external magnetic field sensitivity (for non-magnetic version)
- Vacuum versions available



## Motor Performance Specifications

	max velocity (mm/sec)	dynamic stall force (N)	static hold force (N)	static stiffness (N/ $\mu$ )	preload on stage (N)	Kf force constant (N/volt commanded)
<b>HR1</b>	250	4	3.5	1	18	.75
<b>HR2</b>	250	8	7	1.8	36	1.5
<b>HR4</b>	250	16	14	2.8	72	3
<b>HR8</b>	250	32	28	3.5	144	6

**Note:** All motor performance data is based on using Nanomotion ceramic motors and amplifiers. All dimensions in mm

## Environmental

Operating Temperature:	0 to 50°C
Storage:	-20°C to +70°C
Humidity:	0 to 80%, non condensing
-V Vacuum Motors:	to 10 <sup>-7</sup> torr after bake out
-U Ultra-high Vacuum Motors:	to 10 <sup>-10</sup> torr after bake out
Max Bake Out Temperature:	120°C for -V motors, 140°C for -U motors

Dimensions (European View)

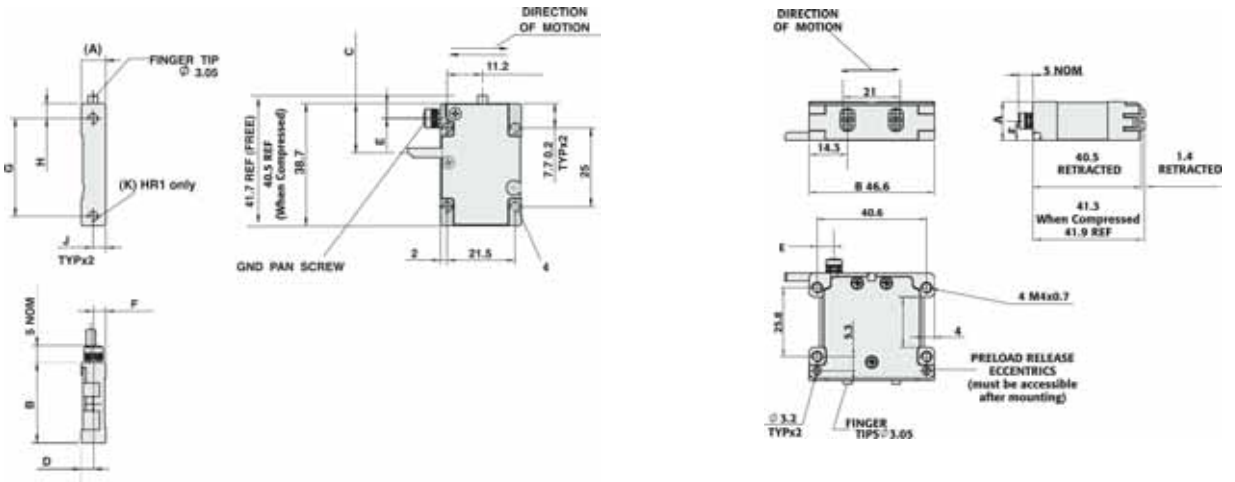

	A motor height	B motor width	C cable exit	D	E gnd screw	F gnd screw	G side mtg	H side mtg	J side mtg	K motor type	motor weight (grams)
HR1-1-S	8	25.7	15.6	4.7	4.7	3.8	31	4.7	4	M3x0.5	30
HR1-1-V	8	25.7	15.6	4.7	4.7	3.8	31	4.7	4	M3x0.5	20
HR1-1-U	7.7	25.5	NA	NA	4	4	NA	NA	NA	NA	20
HR2-1-S	12.7	25.7	15.6	9.7	4.7	6	NA	NA	NA	NA	60
HR2-1-V	12.7	25.7	15.6	9.7	4.7	6	NA	NA	NA	NA	40
HR2-1-U	12.7	25.5	NA	NA	4	6	NA	NA	NA	NA	40
Terminal Mtg for U motors											
HR4-1-S	14.4	46.6	Bottom Back	9.3	7.2	NA	NA	NA	NA	NA	73
HR4-1-V	14.4	46.6	Left or Right	9.3	7.2	NA	NA	NA	NA	NA	73
HR4-1-U	14.9	46.6	NA	NA	NA	NA	NA	NA	6	NA	73
HR8-1-S	23.3	46.6	Bottom Back	9	12	NA	NA	NA	NA	NA	170
HR8-1-V	23.3	46.6	Left or Right	9	12	NA	NA	NA	NA	NA	120
HR8-1-U	23.8	46.6	NA	NA	NA	NA	NA	NA	12	NA	120

**Note:** All dimensions in mm  
 -S motors are Standard  
 -V motors are Vacuum Rated to 10<sup>-7</sup> Torr (use VN for Vacuum & Non-Magnetic)  
 -U motors are Vacuum Rated to 10<sup>-10</sup> Torr and are Non-Magnetic  
 -N motors are Non-Magnetic, for MRI environments

Envelope of Performance

curve	duty cycle	25°C		50°C		Vacuum	
		max. continuous operation time	duty cycle	max. continuous operation time	duty cycle	max. continuous operation time	duty cycle
a	100%	-	100%	-	100%	-	-
b	100%	-	100%	-	44%	184	-
c	100%	-	92%	137	26%	107	-
d	100%	-	62%	93	17%	72	-
e	78%	67 seconds	47%	70	13%	55	-
f	56%	67 seconds	33%	50	9%	39	-
g	50%	67 seconds	30%	45	8%	35	-

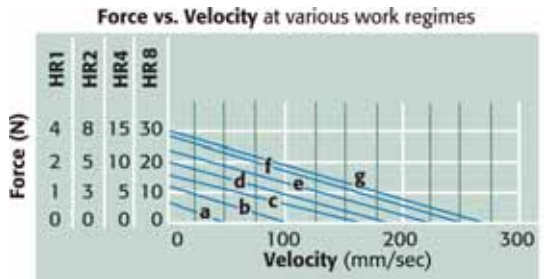

Nanomotion's family of LS Series motors are available in configurations with 2, 4 and 8 elements. The LS series provides unmatched resolution for repetitive step and settle applications with zero servo dither when in position. The LS series is capable of reaching step sizes in the few nanometers range with maximum speeds of up to 20mm/sec.



## Features

- Unlimited travel
- Step resolution better than 20nm
- No intrinsic magnetic field
- No external magnetic field sensitivity
- Vacuum versions available



## Motor Performance Specifications

	max velocity (mm/sec)	dynamic stall force (N)	static hold force (N)	static stiffness (N/μ)	preload on stage (N)	Kf force constant (N/volt commanded)
<b>LS2</b>	50	2	2	1.6	18	.1
<b>LS4</b>	50	4	4	2.5	36	1.5
<b>LS8</b>	50	8	8	3.5	72	4

**Note:** All motor performance data is based on using Nanomotion ceramic, with motors and amplifiers

## Environmental

Operating Temperature:	0 to 50°C
Storage:	-20°C to +70°C
Humidity:	0 to 80%, non condensing
-V Vacuum Motors:	to 10 <sup>-7</sup> Torr after bake out
Max Bake Out Temperature	120°C for -V motors

## Dimensions (European View)

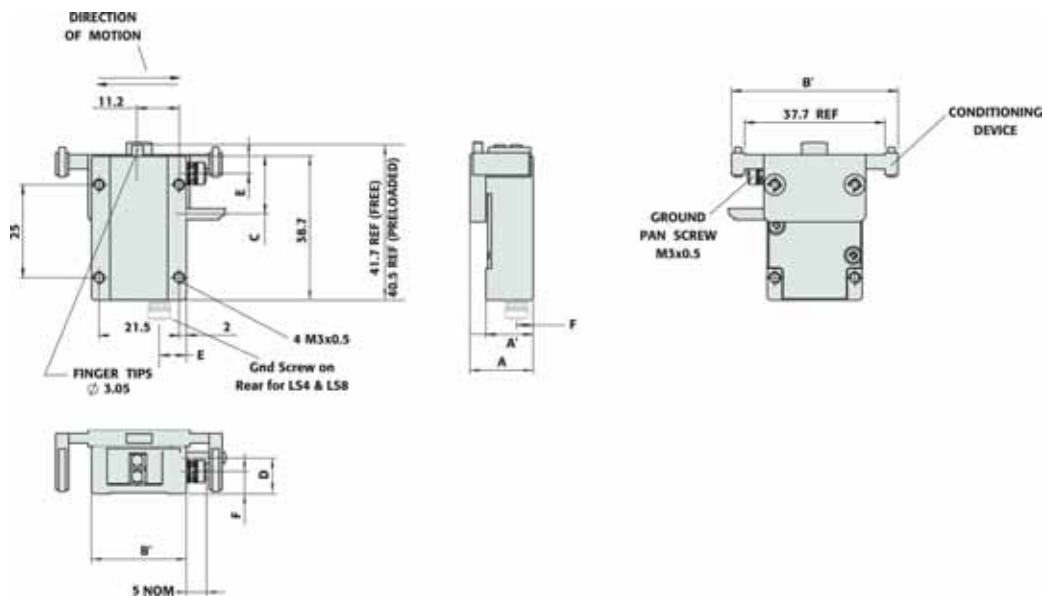

	A motor height	A' height w/o conditioning	B motor width	B' width w/o conditioning	C cable exit	D cable exit	E gnd screw	F gnd screw	Motor weight (grams)
LS2-1-S	17	12.7	44.7	25.7	15.6	9.7	4.7	6	65
LS4-1-S	18.9	14.4	60	46.6	Bottom Back		9.3	7.2	89
LS8-1-S	27.8	23.3	60	46.6	Bottom Back		9.3	11.8	175

**Note:** All dimensions in mm  
 -S motors are Standard  
 -V motors are Vacuum Rated to 10<sup>-7</sup> Torr (use VN for Vacuum & Non-Magnetic)

## Envelope of Performance

curve	25°C		50°C	
	duty cycle	max continuous operation time	duty cycle	max continuous operation time
a	100%	-	100%	-
b	100%	-	100%	-
c	100%	-	92%	137
d	100%	-	62%	93
e	78%	67 seconds	47%	70
f	56%	62 seconds	33%	50
g	50%	56 seconds	30%	45

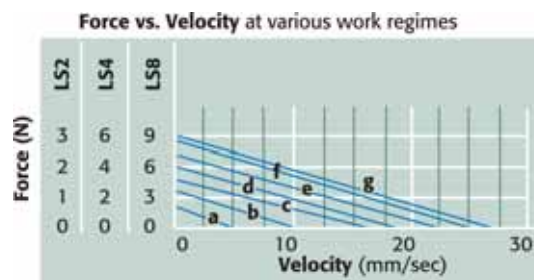

The ST Series Piezoelectric Motor is the smallest motor of its kind. The ST provides high resolution motion control for linear or rotary devices in a fraction of the space of traditional mechanisms. The ST is ideal for small stepping as well as continuous travel, with the ability to make step increments in the tens of nanometers and the ability to operate at speeds up to 250mm/sec.

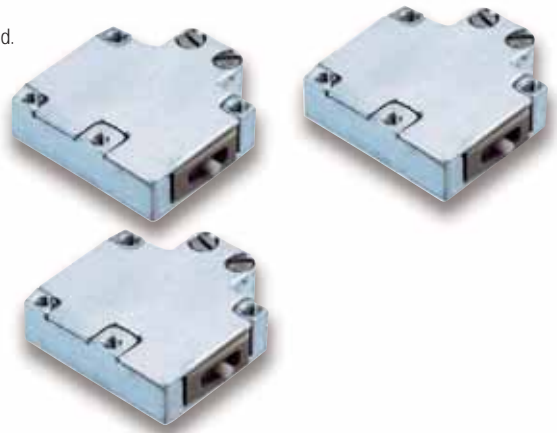

## Features

- The smallest standard Piezo-Electric package
- Unlimited travel
- Wide dynamic velocity range— from 1µm/sec to 250mm/sec
- Excellent move & settle
- Standard and low speed version for high resolution
- No intrinsic magnetic field
- No external magnetic field sensitivity

## Dimensions (European View)

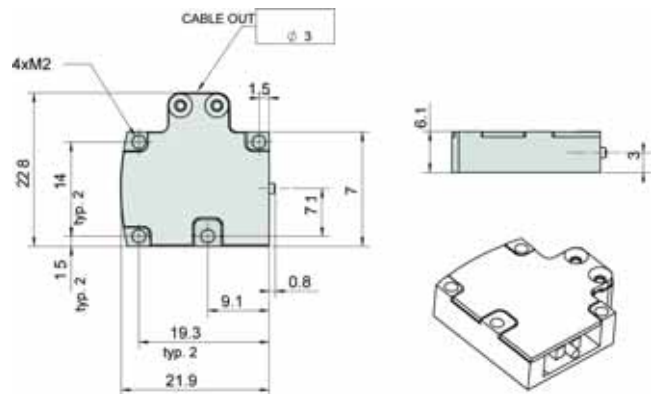

## Motor Performance Specifications

	max velocity (mm/sec)	dynamic stall force (N)	static hold force (N)	static stiffness (N/µ)	preload on stage (N)	Kf force constant (N/Volt Commanded)
ST-1-S	250	1.2	1	.15	8	.1
ST-1-V	250	1.2	1	.15	8	.1

**Note:** All Dimensions are in mm.

## Environmental

Operating temperature: 0 to 50°C  
 Storage: -40°C to +70°C  
 Humidity: 0 to 80%, non condensing

Nanomotion's Edge motor is the smallest industrial motor of its kind available in the marketplace today. Providing unlimited linear or rotary motion, the Edge motor offers extensive opportunities in applications that suit a wide range of industries. The Edge motor works with a uniquely designed, compact ASIC-based driver, and can be operated with any servo controller.

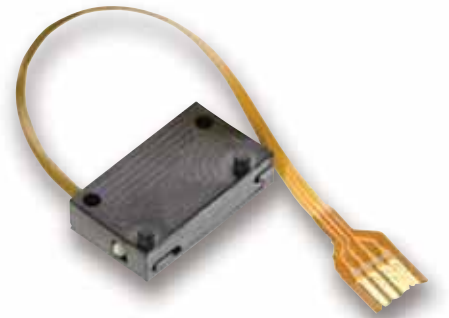

## Features

The Edge can be easily integrated into most bearing structures, and is ideal for mass production opportunities.

- Extremely small dimensions
- Low power consumption
- ASIC drive and control
- Wide dynamic velocity range
- Motor weight of 0.55g
- Excellent move and settle characteristics
- Inherent brake at power off

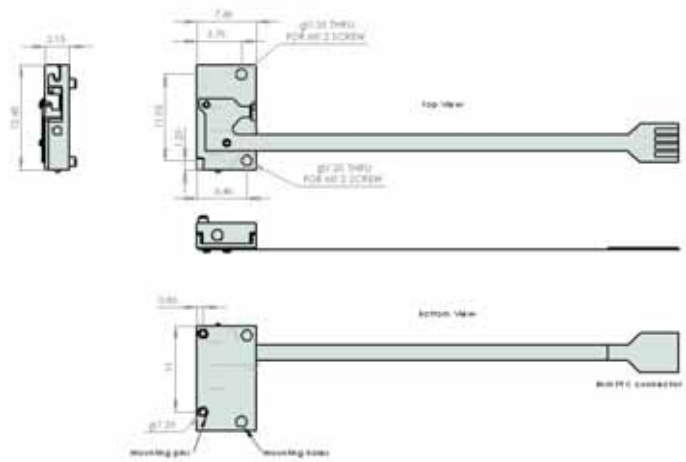

## Motor Performance Specifications

	max velocity (mm/sec)	dynamic stall force (mN)	static hold force (mN)	static stiffness (N/μ)	preload on stage (N)	Kf force constant (mn/volt commanded)	kv force (N · sec/m)
EM1-S-0	120	300	310	.075	1.8	30.5	1.6
EM1-V-0	120	300	310	.075	1.8	30.5	1.6

**Note:** All motor performance data is based on using Nanomotion ceramic motors and amplifiers

## Environmental

Maximum Velocity: 120 [mm/sec]  
 Dynamic Stall Force: 300 [mN]  
 Static Holding Force: 300 to 320 [mN] (reference value)  
 Non-energized Stiffness: 0.06 to 0.09 [N/μ]  
 Nominal Preload on Stage: 1.65 to 2.0 [N]  
 Kf: 30.5 mN/VoH command with AB5 driver (+/-15% tolerance)  
 40.6 mN/VoH command with AB1 driver (+/-15% tolerance)

Kfv: -1.6307 Nsec/m  
 Offset: 2-3 [V] (driver dependent)  
 Attainable Resolution: better than 100 nm  
 Nominal Lifetime: 20,000 hours under nominal operating conditions

Nanomotion's ASIC driver can support the Edge motor working in either the traditional AB1A mode or AB5 mode (with linear voltage to velocity profile). The AB1A mode can support up to two motors while the AB5 mode will support one Edge motor.

The ASIC driver has specific I/O for enable and fault functionality. The driver operates as a slave in the IIC protocol. The communication is performed by exchanging messages between the master and the slave. The master initiates both types of messages:

- 1.) Master>Slave: the master sends a message to the slave.
- 2.) Slave>Master: The slave sends a message to the master.



## Features

- ASIC based driver
- Up to (2) Edge motors on an axis
- Dual axis for (1) Edge motor per axis
- IIC communication channel
- Available with a mother board for  $\pm 10\text{v}$  analog input
- Small form factor with either a header to mother board or direct FPC connection to the motor
- Supply voltage of 3.3v to 4.2v

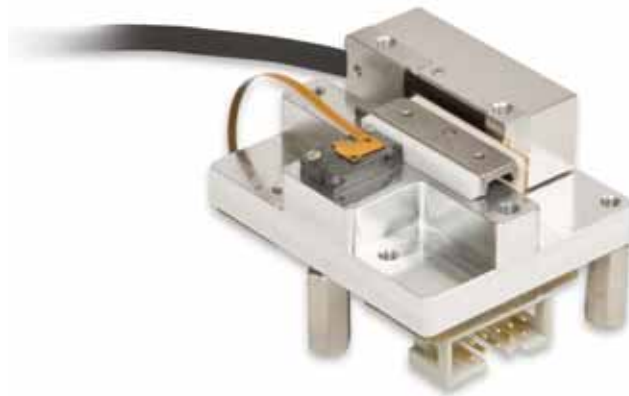

## Operating Specifications

Power Input:	3.3 to 4.2V direct to
Max Motor Output:	12Vrms
Operating Temperature:	-40°C to 70°C
Storage Temperature:	-40°C to 80°C
Operating Humidity:	Up to 80% non-condensing



Nanomotion manufactures and supplies ceramic drive strips, DuraStrips and CCS ceramic coated steel for all motor types. Standard strips, rings and disks are available in a wide variety of sizes and shapes. Nanomotion can also provide custom drive strips/rings for different application requirements.

The mating drive surface is critical to the motor's performance. All specifications are based on using Nanomotion's drive surfaces. Most of Nanomotion's standard drive strips are provided with vacuum compatible, double sided tape for easy mounting. The motor user manual defines the proper mounting procedure.

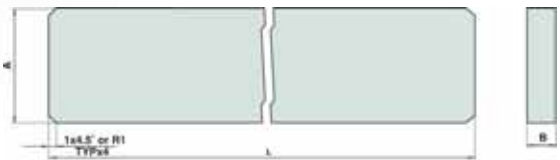

\*Mounted with Double Sided Tape

## Strips

	for use with	a	b	standard lengths**			
standard ceramic							
CS-3-1.5-2.5	EDGE	3	1.5	25	–	–	–
CS-10-1.5-200	ST, HR1, EDGE	10	1.5	200	–	–	–
CS-10-3-XXX***	HR1, HR2, HR4	10	2.7	200	250	300	350
CS-20-3-XXX	HR8	20	2.7	200	250	300	350
ceramic coated steel							
CCS-20-5-XXX	HR1, HR2, HR4, HR8	20	4.8	500	1000	1500	2000

**Note:** \* All ceramics are provided with double sided tape. Please specify in your order form if otherwise required.  
 \*\* For special lengths, consult factory for pricing and availability  
 \*\*\* The XXX represents the required length of the ceramic strip; 50, 100, and 150mm are available as standard. All dimensions are in mm

## Rings & Disks

	motor preload	od	id	thickness
rings				
CR-12-9-5-X	a = axial, r = radial, ra = radial axial	12	9	5
CR-40-32-10-X*	a = axial, r = radial, ra = radial axial	40	32	10
CR-60-40-10-X	a = axial, r = radial, ra = radial axial	60	40	10
CR-100-80-10-X	a = axial, r = radial, ra = radial axial	100	80	10

**Note:** \* The X represents the motor preload required for the ceramic ring, a = axial, r = radial, ra = radial axial

disks				
CD-146-114-1.5	axial	146	114	1.5
CD-192-60-5	axial	192	60	5
CD-192-150-5	axial	192	150	5

Nanomotion manufactures many other ring and disk sizes. Please contact us for non-standard sizes.

## Nanomotion Motion Systems

Nanomotion's XCD is an OEM Drive & Control board designed for applications using our Edge, ST, HR motors (up to HR4). This board level control product can replace a traditional drive & servo control for a single axis application with a very small form factor.

The XCD is intended for volume based applications as the communication and feedback connections are designed into the motherboard, based on customer requirements. The XCD supports, I<sup>2</sup>C, SPI and Uart communication interfaces and takes quadrature encoder input, acting as a complete drive and control.

For additional information on the XCD control boards, please contact Nanomotion.



When the standard stage doesn't quite fit, Nanomotion will design a custom motion system to meet specific application requirements. In some instances, where appropriate, traditional step motors or DC motors may be used to achieve specific performance.

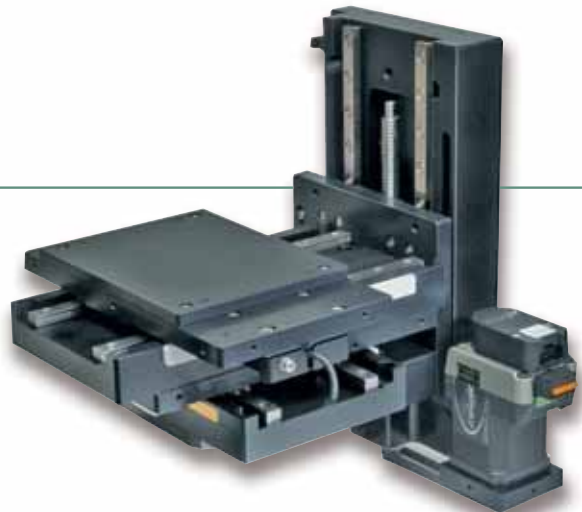

## Features

- Compact design with low profile
- Direct drive Piezo motor with a simple, robust construction
- Optical encoders for high resolution
- Standard atmosphere and vacuum compatible configurations
- Wide range of sizes and travels

## Stage Configurations

series	width	motor options	standard travels
FB050	50mm	HR4	20mm, 50mm, 75mm
FB075	75mm	HR4 or HR8	40mm, 60mm, 100mm, 150mm
FB100	100mm	HR4 or HR8	60mm, 100mm, 150mm, 300mm
FB150	150mm	HR4 or HR8	100mm, 150mm, 200mm

**Note:** Travel lengths to 300mm available in the FB100 and FB150 configurations.

### Encoders

Standard encoder resolution is 0.1µm  
 Optional resolutions: 1µm, 0.5µm, 50nm, 10nm  
 Optional limits and home sensor  
 (FB050 is home only)

### Available Mountings

X/Y  
 X/Z using angle bracket  
 X/Y/Z using angle bracket

## Performance Specifications

	FB050	FB075	FB100	FB150
straightness & flatness	2.5µm/25mm travel	2.5µm/25mm travel	2.5µm/25mm travel	1.5µm/25mm travel
maximum load capacity (in kg)				
20mm travel	2			
40mm travel		5		
50mm travel	5			
60mm travel		5	10	
75mm travel	7			
100mm travel		7	12	20
150mm travel		10	12	25
200mm travel				25

## Motor Performance Specifications

	FB050	FB075	FB100	FB150
Driving Force (in N)				
HR4	16	16	16	16
HR8		30	30	30
Static Holding Force (in N)				
HR4	12	12	12	12
HR8		25	25	25
Position Repeatability				
0.1µm standard		±0.5µm		
10nm optional		±50nm		
50nm optional		±200nm		
0.5µm optional		±2µm		
1.0µm optional		±3µm		

**Note:** All standard Nanomotion stages can be combined to create multi axis configurations. Hole pattern requirements vary based on the sizes of the stages to be mounted. Please contact Nanomotion for hole pattern details.

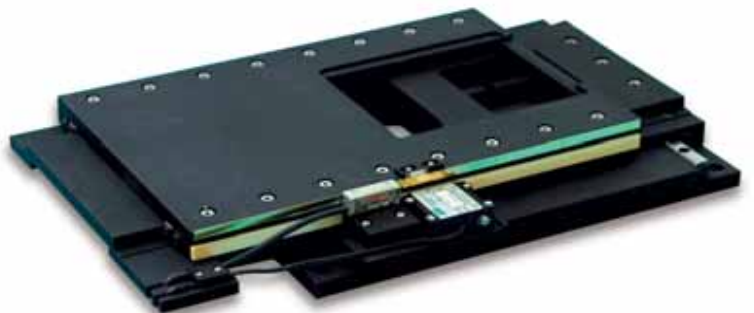

## Performance Specifications

- Compact stage design with low profile
- Direct drive motor with simple, robust construction
- Linear encoder mounted in the center for optimum positioning
- Easily configurable in multi-axis
- Wide range of slide size, travels and motor size

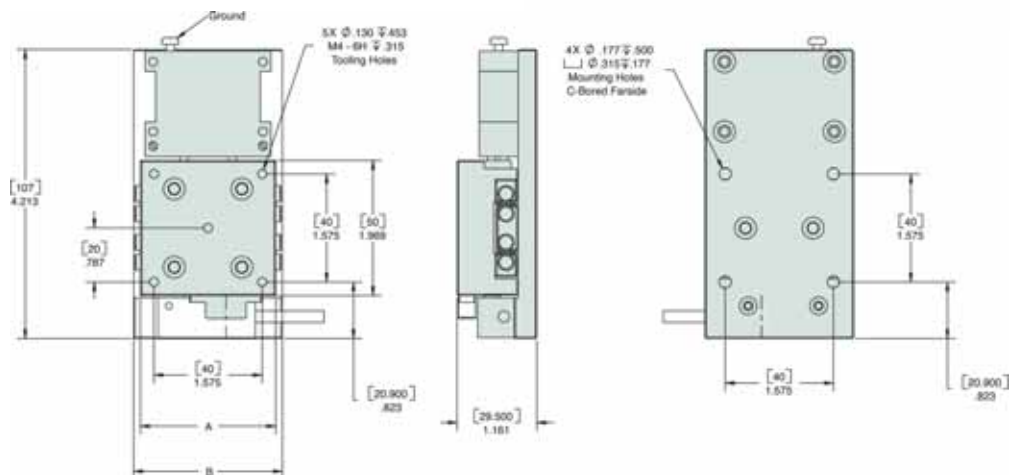

## Motor Performance Specifications

	travel (mm)	A (mm)	B (mm)	dynamic stall force (N)	stage mass (g)	moving mass (g)
FB050-020-0.1M4	20	50	55	16	400	150
FB050-050-0.1M4	50	75	80	16	610	226
FB050-075-0.1M4	75	100	105	16	700	400

**Note:** All standard FB stages are provided with .1µm resolution linear encoders.

Encoder Options part suffix	resolution
-1.0M	.1µm Optional
-0.5M	.5µm Optional
-50N	50nm Optional
-10N	10nm Optional

## Performance Specifications

- Compact stage design with low profile
- Direct drive motor with simple, robust construction
- Linear encoder mounted in the center for optimum positioning
- Easily configurable in multi-axis
- Wide range of slide size, travels and motor size

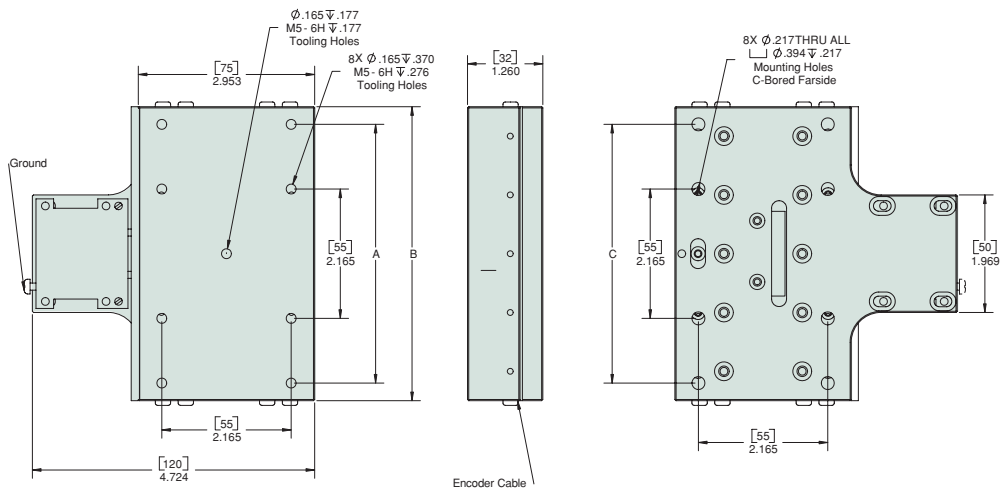

## Motor Performance Specifications

	travel (mm)	A (mm)	B (mm)	C (mm)	dynamic stall force (N)	stage mass (g)	moving mass (g)
FB075-040-0.1M4	40	n/a	75	n/a	16	650	302
FB075-060-0.1M4	60	n/a	100	n/a	16	920	405
FB075-060-0.1M8	60	n/a	100	n/a	32	1035	412
FB075-100-0.1M4	100	110	125	110	16	1125	505
FB075-100-0.1M8	100	110	125	110	32	1230	515
FB075-150-0.1M4	150	160	175	160	16	1515	710
FB075-150-0.1M8	150	160	175	160	32	1620	720

**Note:** All standard FB stages are provided with .1µm resolution linear encoders.

Encoder Options part suffix	resolution
-1.0M	.1µm Optional
-0.5M	.5µm Optional
-50N	50nm Optional
-10N	10nm Optional

## Features

- Compact stage design with low profile
- Direct drive motor with simple, robust construction
- Linear encoder mounted in the center for optimum positioning
- Easily configurable in multi-axis
- Wide range of slide size, travels and motor size

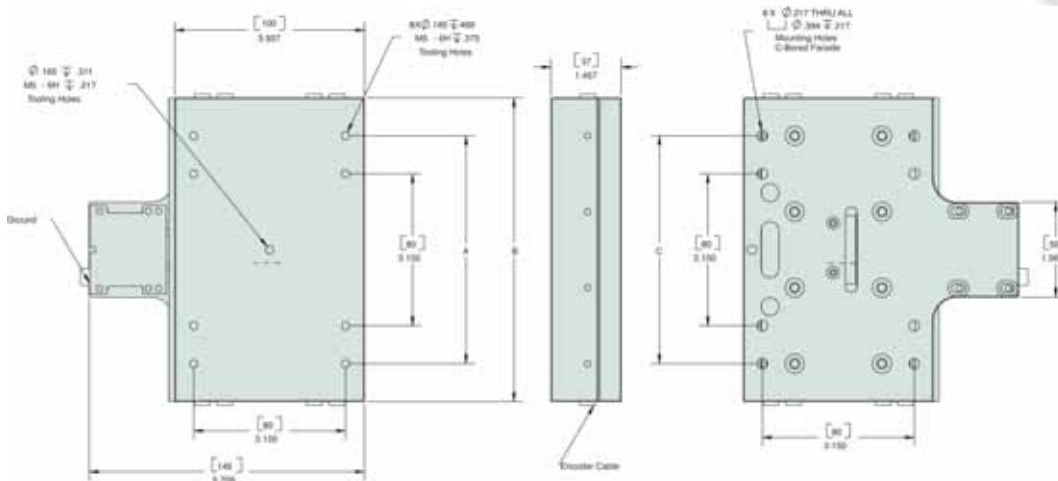

## Motor Performance Specifications

	travel (mm)	A (mm)	B (mm)	C (mm)	dynamic stall force (N)	stage mass (g)	moving mass (g)
FB100-060-0.1M4	60	n/a	120	n/a	16	1580	690
FB100-060-0.1M8	60	n/a	120	n/a	32	1690	700
FB100-100-0.1M4	100	120	160	120	16	2040	920
FB100-100-0.1M8	100	120	160	120	32	2145	930
FB100-150-0.1M8	150	160	200	160	32	2625	1160

**Note:** All standard FB stages are provided with .1µm resolution linear encoders.

Encoder Options part suffix	resolution
-1.0M	.1µm Optional
-0.5M	.5µm Optional
-50N	50nm Optional
-10N	10nm Optional

## Features

- Compact stage design with low profile
- Direct drive motor with simple, robust construction
- Linear encoder mounted in the center for optimum positioning
- Easily configurable in multi-axis
- Wide range of slide size, travels and motor size

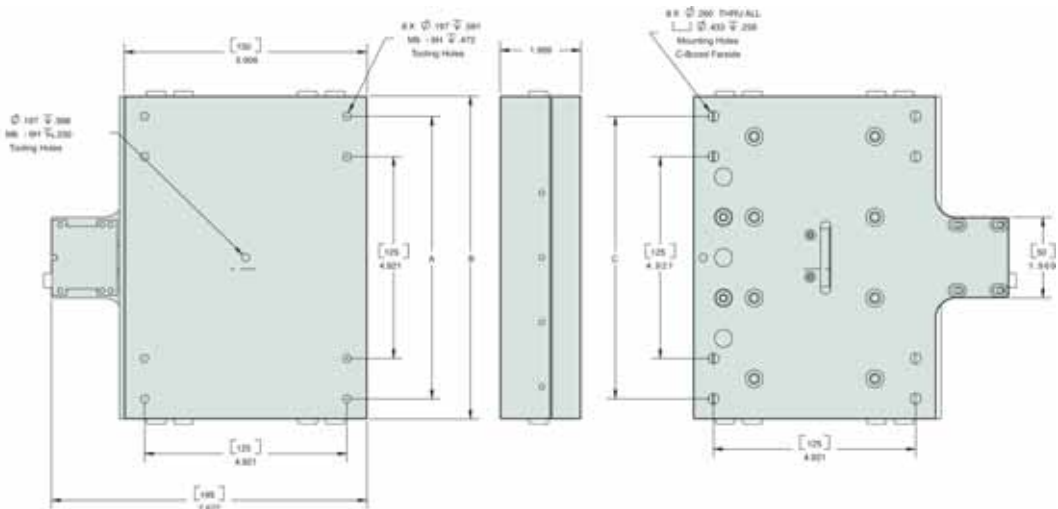

## Motor Performance Specifications

	Travel (mm)	A (mm)	B (mm)	C (mm)	Dynamic Stall Force (N)	Stage Mass (g)	Moving Mass (g)
FB150-100-0.1M8	100	n/a	150	n/a	32	3940	1600
FB150-150-0.1M8	150	175	200	175	32	5095	2125
FB150-200-0.1M8	200	225	250	225	32	6275	2660
FB150-300-0.1M8	300	325	350	325	32	8635	3730

**Note:** All standard FB stages are provided with .1µm resolution linear encoders.

Encoder Options part suffix	resolution
-1.0M	.1µm Optional
-0.5M	.5µm Optional
-50N	50nm Optional
-10N	10nm Optional

Nanomotion's FBR Rotary stage provides the most compact footprint for precision rotary motion. A 60mm diameter ceramic ring surrounds a precision crossed roller rotary bearing with a non-contact optical encoder. The FBR60 can be configured with encoder resolutions to 0.5 arc seconds and one or multiple motors for different speed/torque requirements.

FBR60 Rotary Stages are available in standard, Vacuum and UHV configurations and are provided with a through hole in the center to allow for wires or other devices that require a center feed.



### Features

- Extremely compact footprint & low profile
- High stiffness crossed roller bearing
- Standard and vacuum configurations
- Easily configurable in multi-axis
- High resolution optical encoder

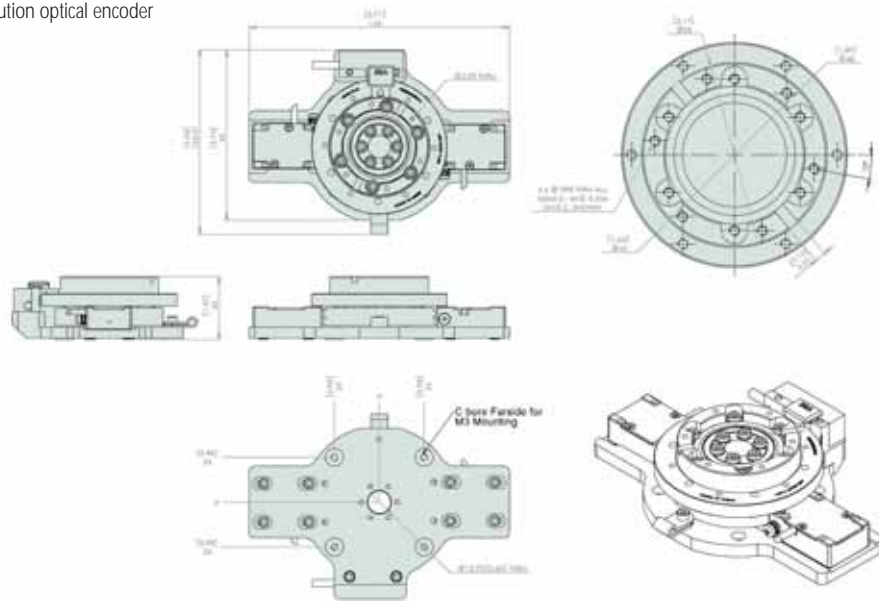

### Performance Specifications

Nanomotion also configures the FBR60 with (1) HR2 motor, to reduce footprint with lighter loads. Contact factory for more details.

	velocity	resolution	accuracy	torque	radial runout	flatness of rotation	load capacity
<b>FBR60-360-5.0</b>	360°/sec	5 arc sec	10 arc sec	0.22Nm to 0.44Nm	5µm	5µm	5kg (horz)
<b>FBR60-360-0.5</b>	360°/sec	0.5 arc sec	10 arc sec	0.22Nm to 0.44Nm	5µm	5µm	5kg (horz)



Nanomotion's Z-wedge stage utilizes crossed roller bearings on an incline to drive a center wedge through a top and bottom plate that coupled together. This horizontal motion results in pure vertical translation of the top surface of the stage.

Using a Z-wedge configuration facilitates easy access over the entire surface and from all sides. Linear position encoding is done directly on the vertical translation eliminating any errors from the angle of the wedge.



## Features

- Horizontal drive for vertical translation
- Direct position feedback with resolution from 100nm to 5 nm
- Capacity to 2kg
- Unobstructed work surface
- Larger Z wedge stages available

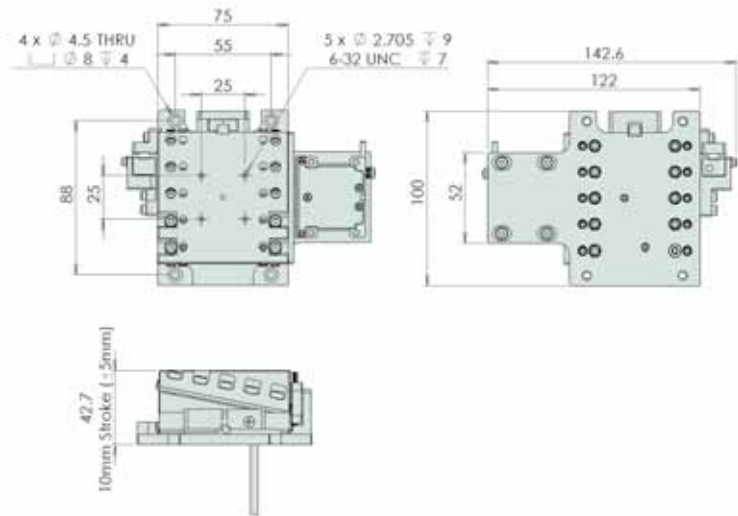

## Dimensions & Specifications

	motor	vertical straightness	position sensor	height	max. load capacity
<b>FBR-075-10-10N</b>	HR4	2.5µm/25mm	10 nanometer	Min: 38.0mm Max: 48.0mm	2kg
<b>FBR-075-10-0.1M</b>	HR4	2.5µm/25mm	0.1 micron	Min: 38.0mm Max: 38.0mm	2kg

Nanomotion's FGB Series geniometer stages provide tilting motion about a pivot axis above the stage. The stage design provides the ability to couple two axes together to tip and tilt around a common pivot axis. The geniometer stages use a direct optical encoder with a tape scale on the curved surface, providing resolution down to 1 arc second.



### Features

- 4 available pivot axes to combine tip/tilt around a common point
- Range of encoder resolutions available
- Easily configured with any "FB" Series axes

### Dimensions & Specifications

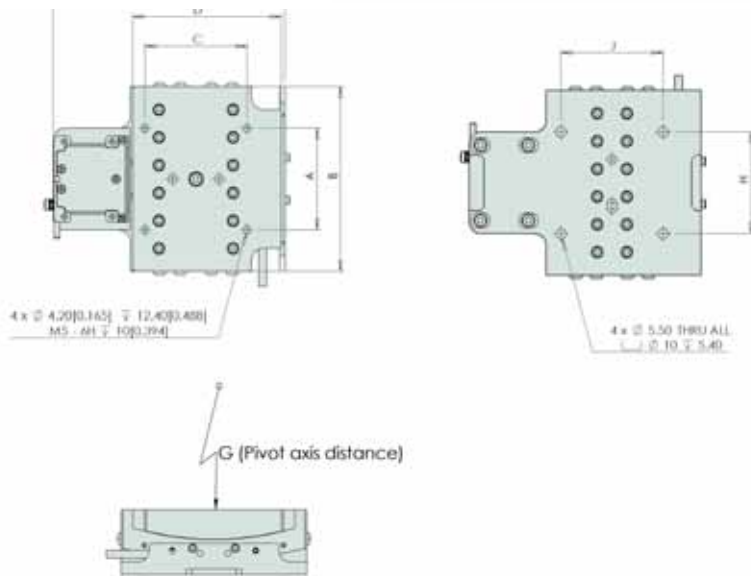

	travel	A mm	B mm	C mm	D mm	E mm	F mm	pivot axis (G) mm	H mm	J mm	dynamic stall force (N)	stage mass (g)	moving mass (g)	load capacity (kg)
85 HR2 Geniometer	+/-10°	50	70	50	73	123	25	71	50	50	8	480	260	2
110 HR2 Geniometer	+/-10°	50	70	50	73	123	25	96	50	50	8	480	260	2
125 HR4 Geniometer	+/-10°	55	100	55	76	129	35	102	55	55	16	940	500	2
160 HR2 Geniometer	+/-10°	55	100	55	76	129	35	137	55	55	16	940	500	2

## Nanomotion offers 5 types of amplifiers to facilitate best performance of the motors.

**AB1A-** is the standard, heavy duty amplifier, widely used.

**AB1A-3U-** a board level AB1A amplifier card, in 3U format for motherboard interface.

**AB2-** facilitates additional ultra high resolution capabilities (UHR), down to 1 nanometer, using the unique DC mode.

**AB4-** a compact amplifier, powered by 12V supply.

**AB5-** the innovative linearized amplifier, yields excellent motion performance with any standard controller firmware.

**AB5-3U-** a board level AB5 amplifier card, in 3U format for motherboard interface.



unique functionality	<b>AB1A</b> nanomotion basic	<b>AB1A-3U</b> board level 3U format	<b>AB2</b> DC mode for ultra high resolution	<b>AB4</b> compact amplifier package	<b>AB5</b> linear response, operates with standard servo	<b>AB5-3U</b> linear response operates with standard servo
<b>Supply Voltage (Vdc)</b>	48	48	24	12	24	24
<b>Packaging</b>	panel mount box	board level 3u format	panel mount box	small panel mount box	panel mount box	board level 3U format
<b>Max # of HR Elements (1)</b>	32	32	16	4	32	32
<b>Max Motor Cable Length (3)</b>	15	15	20	20	20	20
<b>Input Signals (2)</b>	±10Vdc	±10Vdc	±10Vdc	±10Vdc spi digital	±10Vdc	±10Vdc
<b>Modes of Operation</b>	velocity step gate	velocity step gate	velocity step gate	velocity step gate UHR position	velocity step gate	velocity step gate

	<b>AB1A, AB1A-3U</b>		<b>AB2, AB5, AB5-3U</b>		<b>AB4</b>	
	regular cable	low capacitance cable	regular cable	low capacitance cable	regular cable	low capacitance cable
<b>1HR element</b>	0.5 to 5	0.5 to 8	0.5 to 10	0.5 to 20	0.5 to 10	0.5 to 20
<b>2HR elements</b>	0.5 to 5	0.5 to 8	0.5 to 10	0.5 to 20	0.5 to 10	0.5 to 20
<b>4 HR elements</b>	0.5 to 10	0.5 to 15	0.5 to 10	0.5 to 20	0.5 to 10	0.5 to 20
<b>8 HR elements</b>	0.5 to 10	0.5 to 15	0.5 to 10	0.5 to 20	NA	NA
<b>16 HR elements</b>	0.5 to 10	0.5 to 15	0.5 to 10	0.5 to 20	NA	NA
<b>32 HR elements</b>	0.5 to 10	0.5 to 15	0.5 to 10 (AB5)	0.5 to 20 (AB5)	NA	NA
<b>1 ST element</b>	3	3	NA	0.5 to 10	NA	0.5 to 10m
<b>2 LS elements</b>	0.5 to 5	NA	NA	NA	NA	NA
<b>4 LS elements</b>	0.5 to 5	NA	NA	NA	NA	NA
<b>8 LS elements</b>	0.5 to 5	NA	NA	NA	NA	NA

The AB1A amplifier is a single axis digital driver that can run one or multiple Nanomotion motors in parallel. While operating in a closed loop servo system, the driver works as a velocity amplifier, receiving a +/- 10 volt analog command from the controller. The controller signal translates into AC voltage at 39.6 kHz to run the motor. In an open loop mode the amplifier can receive a signal from an external joystick, providing motion in a continuous or stepping mode.



## Features

- Digital drive handles up to 32 elements
- Available in Eurocard 3μ format
- +/- 10V input from servo control
- Joystick input for open loop operation
- 2 optically isolated limits
- Card interface is 48 pin 3 row connector

## Amplifier Specifications

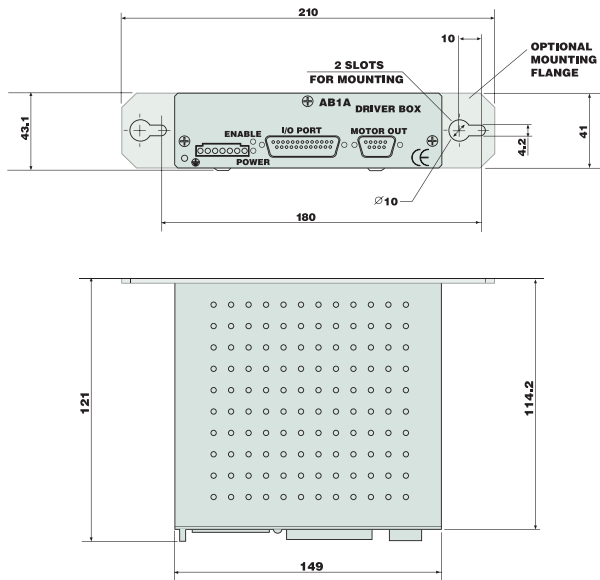

Driving Capability: up to 32 elements (4 HR8 motors)

### Analog Control Input

Input Voltage Range: +/-10V  
 Input Impedance: 10 KΩ  
 Input Low Pass Filter: 2.7 KHz  
 Input Sampling Resolution: 10 bits

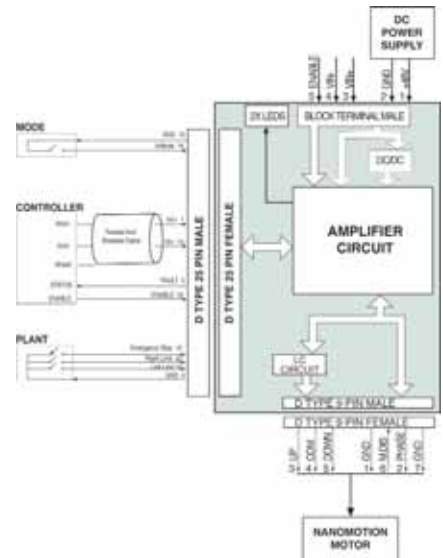

## Environmental

Operating temperature: 0 to 50°C  
 Storage Temperature: -40°C to +70°C  
 Humidity: 0 to 80%

## Electrical

Power Input: +48Vdc±5%  
 Max Motor Output: 270 to 280Vrms  
 Power Consumption w/o Load: +48Vdc/0.125A  
 Power Consumption with Max Load: +48Vdc/6.5Amax

The AB2 amplifier combines the normal Velocity mode of the AB1A amplifier, for servo operation, with the DC mode, for Ultra-High resolution positioning. The DC mode treats the motor as a traditional piezo actuator, providing the ability to make discrete moves at the 1 nanometer level.



The DC mode uses the same  $\pm 10\text{v}$  analog signal from the controller output and translates it to a  $\pm 300$  nanometer position move capability, with 1 nanometer resolution. This function can be operated in an open loop or closed loop manner. The switching between the Velocity mode and DC mode is done seamlessly through a discrete input signal.

## Features

- Ultra high resolution capability using DC mode
- Digital drive handles 16 HR motor elements
- Requires 24Vdc supply input
- Cable length up to 20m
- Over current and over voltage protection

## Environmental

Operating Temperature:	0 to 50°C
Storage:	-40°C to +70°C
Humidity:	up to 80%, non condensing

## Electrical

Power Supply Input:	+24 Vdc $\pm 5\%$ (stabilized)
Max Motor Output Voltage:	280 Vrms
Power Consumption without Load:	+24 Vdc/200 mA
Power Consumption with Max Load:	+24 Vdc/5A

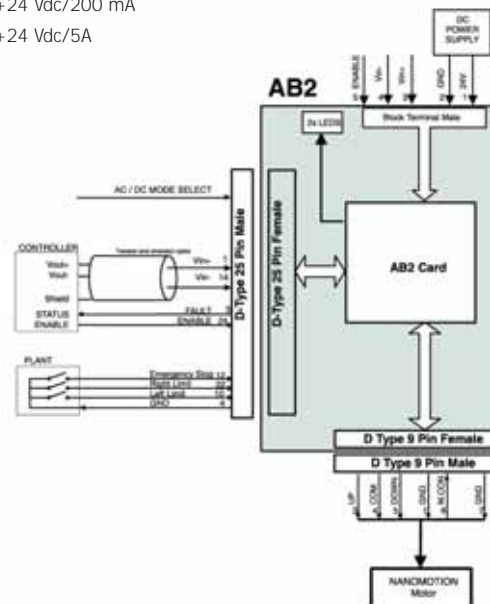
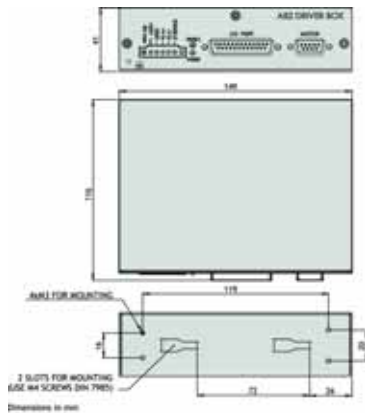

The AB4 amplifier offers the same performance as the AB1A, in a reduced package. The AB4 operates off of 12Vdc supply input and can drive up to 4 HR motor elements total, either (1) 4 element HR motor, or multiple HR motors totaling 4 elements.

The AB4 is the smallest standard motor amplifier and is provided with a 26-pin rear connector (26 pin, two row header). This connector provides access to all functionality (motor, power inputs, limits, and I/O functions), making it easy to integrate. Additional motor and power inputs are available with standard connections on the front.



## Features

- Exceptionally compact mounting
- 12Vdc supply input
- Drives up to 4 HR motor elements
- Cable length up to 20m
- Over current and over voltage protection

## Environmental

Operating Temperature:	0 to 50°C
Storage:	-40°C to +70°C
Humidity:	up to 80%, non condensing

## Electrical

Power Supply Input:	+12 Vdc ±5% (stabilized)
Max Motor Output Voltage:	280 Vrms
Power Consumption without Load:	+12 Vdc/300 mA
Power Consumption with Max Load:	+12 Vdc/3.5A

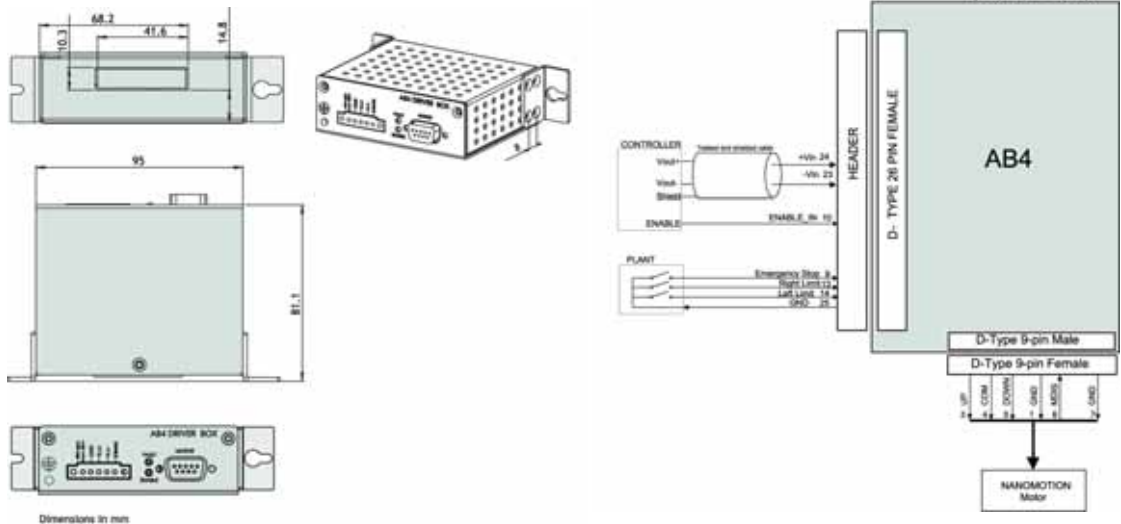

The AB5 amplifier revolutionizes the driving concept for Nanomotion ceramic servo motors, enabling a frictionless and smooth motion throughout the entire velocity range. At stop the inherent brake is activated, maintaining the many advantages of brake at power off. Consequently the control scheme is simplified, facilitating the use of any low cost servo controller to achieve outstanding performance.



As a result the whole range of controllers in the market place can be used with Nanomotion motors, as well as generic control algorithms. No custom algorithm is needed to be used with Nanomotion motors.

In addition, exceptional control performance is achieved at servo systems, showing robust performance at various working conditions.

## Features

- Compatible with any servo controller
- Linear velocity response at full command range
- Brake on or brake off upon command
- Drives up to 32 HR motor elements
- 24 Vdc supply input

## Motor Performance Specifications

Driving Capability:	up to 32 HR motor elements
<b>Analog Control Input</b>	
Input Voltage Range:	±10V
Input Impedance:	10KΩ
Input Low Pass Filter:	2.7 KHz
Input Sampling Resolution:	10 bits + direction

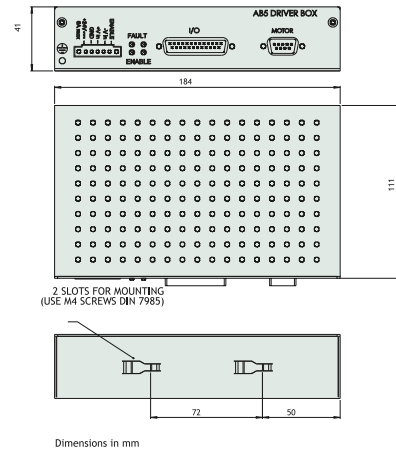

## Environmental

Operating Temperature:	0 to 50°C
Storage:	-40°C to +70°C
Humidity:	up to 80%, non condensing

## Electrical

Power Input:	+24 Vdc ±5% (stabilized)
Power Consumption without Load:	24 Vdc/200 mA
Power Consumption with Max Load:	24 Vdc/10A

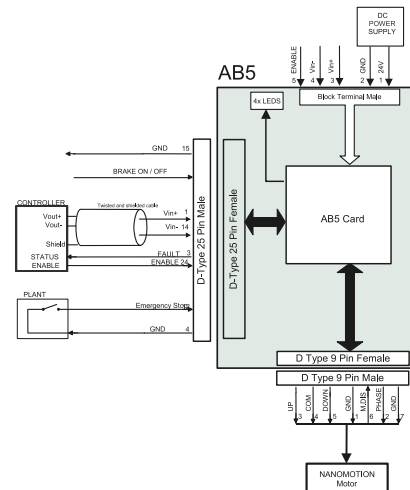

The Flex DC controller/driver is a powerful, simple-to-use controller specifically designed for easy plug & play support of all Nanomotion's motion systems, stages and motors. This full featured motion controller is provided with our AB1A-3U or AB5-3U driver cards built in and a motion control card designed to meet the most demanding motion profiles.

The Flex DC motion controller's GUI based user software makes system set up and programming simple. The interface has data recording capability as well as a host of custom algorithms to optimize performance.



## Features

- Data recording
- Dual axes analog joystick
- Nanomotion algorithms, including ultra high resolution and dead band
- LED indicators on the front panel
- All connectors and power inlets available on the rear panel for easy access

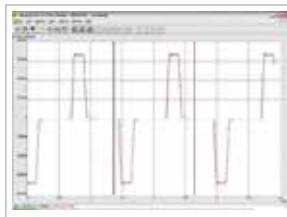

## Flex DC Specifications

<b>Dimensions</b>	2U enclosure	123mm h x 361mm w x 308mm d
<b>Weight</b>	5.2kg (depends on configuration)	
<b>Technical Specifications</b>	up to 2 axes integrated	AB1A or AB5, up to 16 elements
	servo rate 8khz	dac output $\pm 10v$ , 16 bit
	A quad B encoder input	one per axis
	Sin/cos encoder with on board	
	8192 resolution interpolators	optional, (one per axis)
	discrete inputs	one per axis
<b>I/O</b>	8 x digital isolated inputs	
	2 x digital isolated outputs	valid for AB1A configuration only
	2 x digital fast inputs	
	2 x digital fast outputs	
<b>Communication</b>	RS232, CAN-Open, ethernet	
	ascii based RS232 communication protocol	
	full binary, high baud rate, can bus protocol	
<b>Power</b>	universal input voltage	100-240vac, 50-60 hz
	power consumption	130va max
<b>Environmental</b>	ambient operating temperature	0° - 45°C
	storage temperature	up to 70°C
	operating humidity	up to 80%, non-condensing

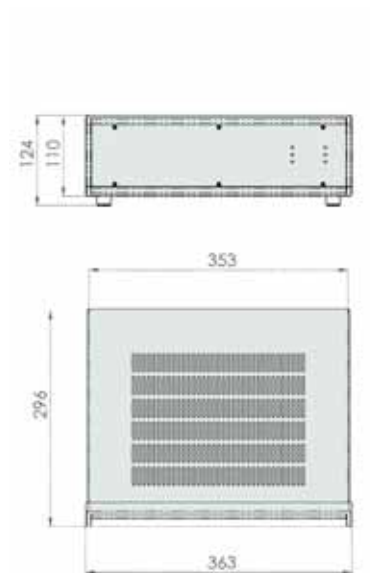



## Technical Guidelines for Using Nanomotion Motors

Nanomotion motors provide direct drive performance for linear or rotary motion. Motion is transmitted through the contact of a finger pushing on a drive strip. The 'friction pair' is specifically selected to yield optimum performance with minimal wear, currently achieving 40,000 hours of operation and working in environments up to Class 10 clean rooms.

To yield the maximum performance benefits of Nanomotion's ceramic servo motors, it is important to understand the operating characteristics of the piezo ceramic elements and the impact that they have on the mechanical structure.

As a direct drive, the Nanomotion motor is sized by the basic principles of  $F = MA$  (plus the resistance of the bearing structure & the force of gravity if on an incline or vertical). While this is a basic sizing method, one must calculate the maximum speed and force necessary to meet the application performance requirements and size the motor properly, operating within the defined EOP (Envelope of Performance).

**NOTE:** When operating a direct drive motor vertically, it is recommended that the motor force be 3 times greater than the total vertical load, to facilitate good servo performance.

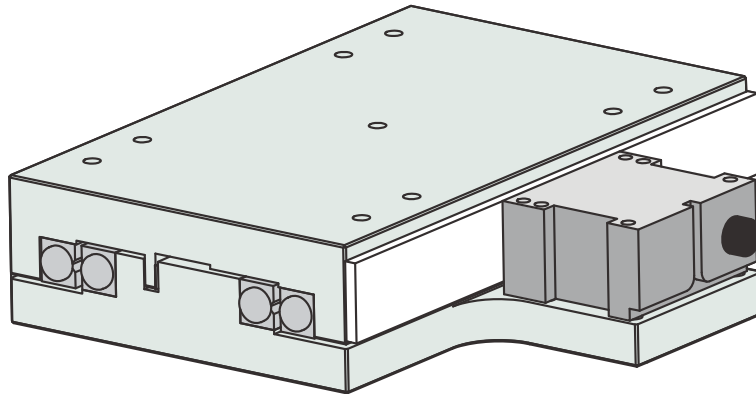

## Managing Normal Force and Stage Stiffness

In addition to the motor sizing, Nanomotion's motor exerts a normal force into the bearing structure in the direction that the motor is mounted and preloaded. This normal force is 5 times the driving force of the motor. Because of this force, it is optimum if the motor can be mounted on the centerline of the bearing structure. Nanomotion motors are in successful operation with:

- Crossed roller linear and rotary bearings
- Recirculating linear guides & shaft bearings.
- Linear and rotary air bearings.
- Angular contact & radial rotary bearings

A key design criteria is the bearing stiffness and preload, to assure successful operation of the motor. A good target value is 40N/micron of bearing stiffness. For less precise applications that do not require 20,000 hours of life, a lower stiffness number is acceptable. For more precise applications, operating in production environments, a minimum stiffness of 50N/micron should be targeted. These stiffness values are easily achieved with conventional bearings on the market today.

For example, an HR1 motor provides 1 lb (4.4N) of thrust, and will create 5 lbs (22N) force into the bearing structure, perpendicular to motion. In addition to the normal force, there is the potential for higher acceleration forces that are placed in the same direction, impacting the bearing. Acceleration forces can be 2 to 3 times greater than the normal force.

The most common linear bearings used in precision motion are crossed rollers and linear recirculating guides. While ball bushings and air bearings are acceptable technologies, they are in the minority.

Rotary applications with Nanomotion motors are quite common as the direct drive motor can eliminate worm gears, belts and other rotary transmissions. In rotary applications there is design flexibility to apply the motor axially, driving on the flat surface of a disk, or radially, driving on the circumference of a ring.

## Rotary Bearings

Typical Axial Mounting

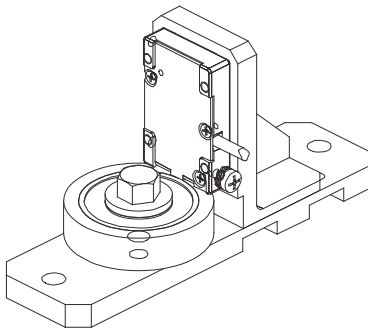

Typical Radial Mounting

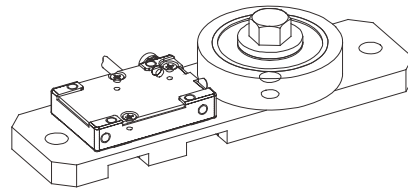

As with linear bearings, the bearing stiffness is critical to the performance of the Nanomotion motor. Moreover, a single motor applied axially will induce a moment load on the bearing whereas a single motor applied radially will induce a side load on the bearing structure. In many rotary applications it is appropriate to consider the use of two smaller motors, mounted 180° apart to maintain a balanced load on the bearing. Mounting two motors that are not 180° apart, with a slightly different angle, can also help to maintain a preload on the bearing and have a positive impact.

In evaluating rotary bearings, there are 3 common types that are utilized in rotary stages:

- Rotary crossed roller
- Angular contact
- Deep groove radial

While the same stiffness criteria apply to rotary applications, 50N/μm, each bearing offers different operating characteristics. The selected bearing should be fully evaluated for its specific load rating and stiffness in the appropriate directions.

## Mechanical Mounting Tolerance

The Nanomotion motor is constructed with a spring behind each motor element. This spring is designed to provide a preload (normal force) as well as allow for mounting inaccuracies. The spring can compensate for 'out of parallel' conditions up to 50μm (.002").

All of the bearing types discussed provide linear accuracies well within these tolerances, but the machined mounting surfaces will contribute to linear accuracy. It should, however, be achievable to control linear straightness to 50μm in a precision motion system.

For systems that require ultrahigh resolution (below 100nm) and smooth constant velocity, it is important to maintain tighter tolerances on the straightness of motion, to optimize the servo performance.

## Mechanical Assembly Procedures and Safeguards

**WARNING: NEVER OPERATE THE MOTOR UN-LOADED,  
WITHOUT PRELOAD AGAINST A NANOMOTION DRIVE STRIP.**

Proper mounting procedures are described in each motor manual, with preload being set by a shim (provided with ST, HR1 & HR2 motors), or a cam (internal to the HR4 & HR8 motors). The motor should be mounted perpendicular to travel, with the arrows on the motor label indicating the direction of travel.

In applications utilizing the HR4 & HR8 motors, it is important to avoid compressing the motor against the ceramic strip, prior to engaging the cams. This additional force will result in a higher than expected preload. If there is a concern about controlling the force during mounting it is acceptable to use a shim, when the finger tips are in a retracted position, up to 15µm thickness. This will assure that the motor elements are not 'over compressed' against the drive strip.

Always make sure the mechanical travel does not permit the motor fingers to become disengaged from the ceramic drive strip. The finger tips should remain in a compressed state at all times.

Most Nanomotion provided drive strips have a 3M acrylic tape bonded to them. Nanomotion can provide the specification on the tape for those customers who require it. When applying the ceramic with the tape, make sure there are no air bubbles and the ceramic strip is applied to a clean surface. After adhering the drive strip, secure it with two drops of epoxy, per the instructions in the manual, to prevent any motion in shear.

## Sizing Example

**Requirements:**

Total moving mass (moving part of stage plus payload),  $M = 1\text{Kg}$

Travel,  $X = 0.01\text{ m}$  (horizontal orientation)

Total move time,  $T = 0.1\text{ sec}$  (not including settling time)

Motion profile: trapezoidal, accelerate for 1/3 of the total time, move at a constant velocity for 1/3 of the total time, decelerate for 1/3 of the total time

**Calculate:**

Acceleration / deceleration,  $A = 4.5 * X / T^2 = 1 * 0.01 / 0.1^2 = 4.5\text{ m/sec}^2$

Maximum velocity,  $V = 1.5 * X / T = 1.5 * 0.01 / 0.1 = 0.15\text{ m/sec}$

Acceleration force,  $F_a = M * A = 1 * 4.5 = 4.5\text{ N}$

Add additional forces (bearing friction, load force, gravity/inclination, etc.) to obtain total force  $F_t$ .

Plot the point  $\{F_t, V\}$  on the Force/Velocity curves. See figure below.

Select the motor whose curve is above the  $\{F_t, V\}$  point. In this case it would be an HR4.

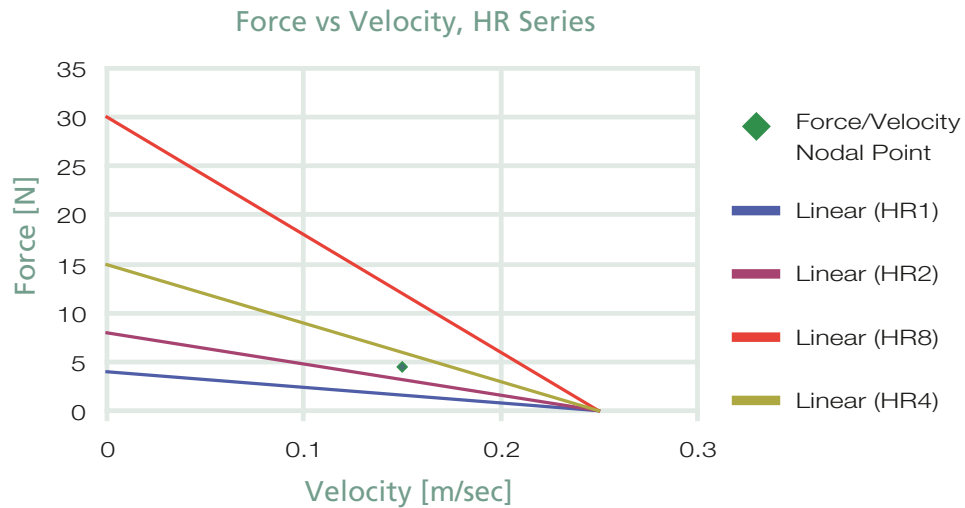

## Settling Time

The achievable settling time is mainly dictated by the damping of the motor and the natural frequency of the system. A typical number of three cycles is required for the motor damping to damp the system vibration along the motion axis, so the settling time will be roughly according to the following formula:

$$T_s = 3/F_r$$

Where  $F_r$  is the natural frequency of the system, and is calculated according to the following formula:

$$F_r = 1/2\pi \sqrt{K/m}$$

Where:

**K** - stiffness of the motor in Newton/meter

**m** - mass of the moving part in Kg

If the desired natural frequency is higher than the one calculated for a given configuration, adding another motor in parallel or in tandem will increase the system's natural frequency due to the increased stiffness. The combined stiffness of several motors is the algebraic sum of the stiffness of the individual motors. One should recalculate the natural frequency using the combined stiffness of the motors. It is worthwhile to note that the effective motor stiffness increases under close loop operation.

Driving vertically with a motor that actuates based on friction requires specific consideration to the static load, separate from the dynamic force. As a rule of thumb, each 4.4N element can drive 120 grams vertically. Beyond this a counter balance should be considered. This can be in the form of a spring, a continuous force gas spring, or opposing weight.

## Electrical Interface

Nanomotion's motors run at resonant frequency and are sensitive to the capacitance of the electrical circuit. Changing cable lengths will affect the total capacitance. There are guidelines provided in Nanomotion's catalog and manuals as to the acceptable cable lengths.

In addition to the cable length from the motor to the amplifier, caution should be used if third party cable is used. Nanomotion provides motors with specific low capacitance cable at:

Standard motors: 64pF/foot

Vacuum motors: 13pF/foot

If the capacitance of the electrical circuit is too high, the full performance of the motor will not be realized. Nanomotion can provide guidelines for testing capacitance.

## Quick Reference– Getting Started

Verify proper stage mechanics with preloaded bearings and appropriate stiffness.

Follow Nanomotion's motor mounting guidelines for preloading and motor orientation with respect to travel & verify that ceramic strip has two drops of epoxy.

Connect the ground wire from the motor to the amplifier.

Verify the connection (jumper) between power supply return and the controller's analog ground.

Condition the motor before tuning, per Motor Installation Manual (Always recondition the motor each time it is disengaged from the ceramic strip).

After conditioning, wipe the ceramic with a clean cloth and IP alcohol without disengaging the motor.

Use "Abort on Position Error" (or other safety mechanism) and appropriate torque limit during initial integration and conditioning. Do not exceed 5v and 50% duty cycle.

Avoid prolonged operation in an unstable condition (excessive vibration) during tuning process.

Consult with Nanomotion with any questions during the set up process.

- Do not operate the motor in an un-loaded (un-mounted) condition
- Do not exceed the duty cycle limits when operating the motor (see Motor Installation Manual)
- Do not allow the motor tips to leave contact with the ceramic strip during operation (Use mechanical hard stops)
- Do not remove the cover of the motor (High Voltage Inside)
- Do not immerse the motor in any liquids

## Motors

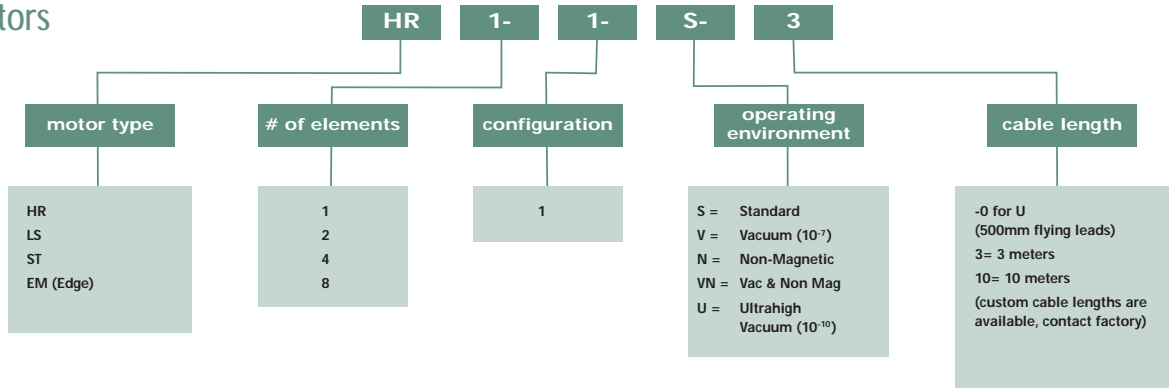

## Amplifiers

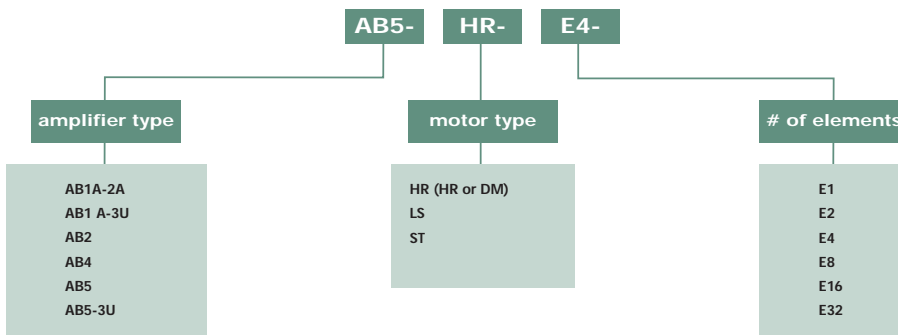

## Ceramics

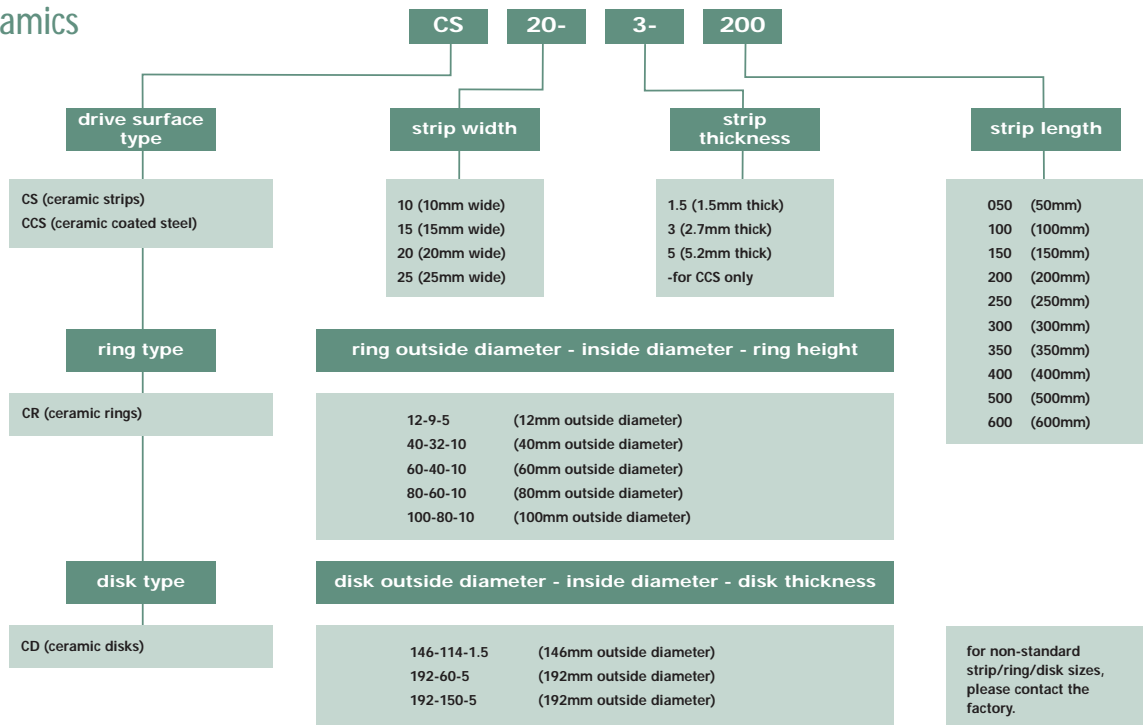



A Johnson Electric Company

**Nanomotion Ltd. Worldwide Headquarters**

**Mordot HaCarmel Industrial Park**

**Yokneam 20692 Israel**

**t: +972 73 2498000**

**f: +972 73 2498099**

**e: [nano@nanomotion.com](mailto:nano@nanomotion.com)**

**Nanomotion Inc. U.S. Headquarters**

**1 Comac Loop, Suite 14B2**

**Ronkonkoma, New York 11779**

**t: (800) 821-6266**

**t: (631) 585-3000**

**f: (631) 585-1947**

**e: [nanoUS@nanomotion.com](mailto:nanoUS@nanomotion.com)**

**[www.nanomotion.com](http://www.nanomotion.com)**