

100 Watts of Pulsed CO₂ Power With 300+ Watts Peak Power

Pulstar^{series} P100



Introducing Synrad's first pulsed Laser!

Synrad Inc. is proud to introduce a first of its kind to its highly acclaimed line of CO₂ lasers with the *pulstar p100*. Featuring 100 Watts of pulsed CO₂ power, the *p100* is ideally suited for a wide variety applications, including high speed drilling and perforating, where quicker results, deeper cutting/marking, and minimal charring and burning on delicate materials is crucial.

With fully integrated RF components, the *p100* completely eliminates the need for external RF cabling and bulky external RF supplies. And, with the same familiar LED indicators, interface, and I/O signal configuration commonly found on many of Synrad's acclaimed Firestar line of lasers, installation/operation is a breeze.

Lighter than competing lasers on the market with a smaller footprint and compact body size, the *p100*'s versatile design and internal beam conditioning make it an excellent choice for manufacturers and OEMs seeking big power in a smaller, easy to handle package.

For more information about the *p100* pulsed CO₂ laser, contact Synrad today, or visit the *p100* online at: www.synrad.com/p100

Specifications:

Model	p100
Average Output Power*	>100W
Peak Pulse Power	> 390W
Mode Quality	M ² ≤ 1.2
Ellipticity	< 1.2
Rise Time	<40µsec
Beam Waist Diameter (full angle at 1/e ²)	5.6mm ± 0.3mm
Beam Divergence (full angle)	< 3mrad
Wavelength (typical)	10.5µm - 10.7µm
Power Stability (guaranteed from cold start)	±7%
Power Stability (typical after two minutes)	±5%
Duty Cycle < 50kHz	0% - 37.5%
Duty Cycle 50-75kHz	0% - 31.5%
Duty Cycle > 75kHz	0% - 25.0%
Polarization	Linear (Vertical)
Cooling	Water
Heat Load (max)	2000W
Flow Rate**	1.5-2.0GPM, < 60PSI
Input Voltage / Current	48 ± 1.0 VDC / 40A
Dimensions (in)	22.2 x 5.2 x 6.1
Dimensions (mm)	563 x 132 x 155
Weight	30.0 lbs / 13.6kg

Specifications subject to change without notice.
*Power level guaranteed for 12 months regardless of operating hours

Firestar p100 Core Features:

- Average power greater than 100W
- Peak pulse power greater than 390W
- Peak pulse energy greater than 190mJ
- Max pulse width of 600µs
- Fast rise time of less than 40µs
- Pulsed up to 100kHz
- Duty cycle range of 0% to 37.5%
- Excellent mode quality
- Hybrid free-space / waveguide resonator
- Built in gas purge port
- Protective optical window
- Easy-to-integrate, compact design
- 15% lighter than competition
- Best-in-class energy efficiency

Outline and Mounting:

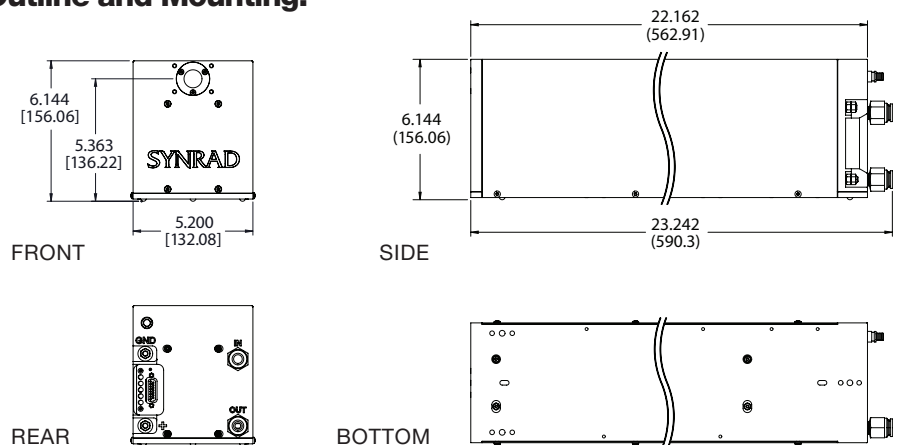

©Synrad, Inc., 4600 Campus Place • Mukilteo, WA 98275, USA
tel: 1.425.349.3500 • fax: 1.425.349.3667 • e-mail: synrad@synrad.com

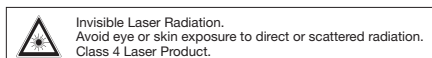

www.gmp.ch

GMP
GENERAL
MICROTECHNOLOGY
& PHOTONICS

SYNRAD
www.synrad.com

2012/05 v2

GMP SA Main office: Avenue des Baumettes 17

CH -1020 Renens

Tél. 021 633 21 21

Fax. 021 633 21 29

info@gmp.ch

GMP SA Büro Zürich: Dübendorfstrasse 11a

CH-8117 Fällanden

Tel. 044 825 34 00

Fax. 044 825 34 01

info@gmp.ch