

TECBL Series

Thermoelectrically Cooled Blue Laser System

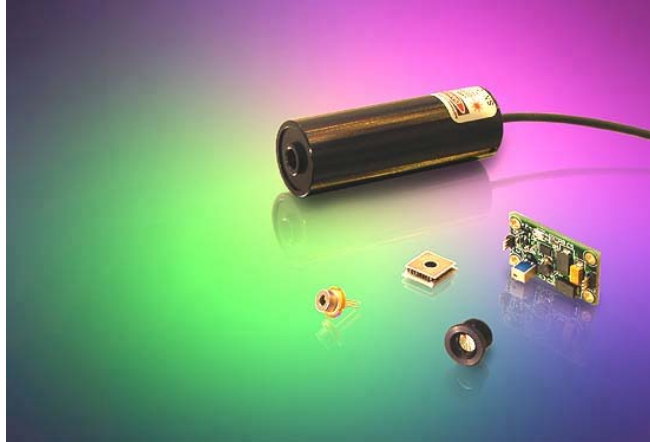

The TECBL Series Thermoelectrically Cooled Blue Laser System is a compact self-contained, highly reliable laser operating at very stable wavelength and power. The build-in temperature controller stabilizes the laser temperature within $\pm 0.01^\circ\text{C}$. The laser output power stability is better than 1% over long term. Extremely stable power, low noise and excellent beam pointing stability of this laser makes it ideal for bioanalytical, measurement and imaging applications. It is powered by a wall mount power adaptor (supplied with the laser) for plug & play operation.

The TECBL series lasers can be customized to include modulation option and beam shaping line optics.

Product Features

- **Integrated TEC & Laser Controller**
- **Low RMS Noise**
- **Excellent Power and Wavelength Stability**
- **Excellent Beam Quality**
- **Compact Size, 1 x 3 inch**
- **ESD and Over-Temperature Protection**
- **Long Life Time**
- **Low Power Consumption, < 2W**

Applications

- **Bioanalytical**
- **DNA Sequencing**
- **Flow Cytometry**
- **Medical Imaging**
- **Capillary Electrophoresis**
- **Confocal Microscopy**
- **Particle Counting**
- **Interferometer**
- **Printing (Reprographics)**



ISO9001:2000 Registered

TECBL Series

Thermoelectrically Cooled Blue Laser System

Specification

Optical	Wavelength	473 nm	
	Power Stability	<0.5%	
	RMS Noise(0~20MHz)	<0.5%	
	P-P Noise	<5% over 8hrs	
	Spatial Mode	Single Mode Laser	
	Spot Size	Adjustable or Collimated (3mm)	
	Divergence at the collimation	< 1 mrad	
	Beam shape	Elliptical (Circular option available)	
	Pointing Stability	< ±25 µrad	
	Polarization	Linear, 100:1	
	Electrical	Laser Drive	CW
		Laser Operating Voltage	6 V DC
Operating Current		<0.5A	
Driving Circuit		Auto Power Control	
Electrical Connections		2.1mm power jack	
Mechanical	Power Supply	100 – 240VAC, 50 – 60 Hz	
	Dimension (Dia x L)	25.4 x 76.2 mm (1" x 3")	
	Weight	75g	
	Operating Temperature	10°C to +40°C(With adequate heat sink)	
	Storage Temperature	-10°C to +50°C	
	Heat Sink Requirements	Recommended for extended use	

Thermal Management: The TECBL Series Laser System is designed to dissipate heat through its body. Please ensure that the mounting brackets are not made of insulating material. For proper heat dissipation and cooling, do not restrict air circulation around the device.

Mechanical Drawing

Laser

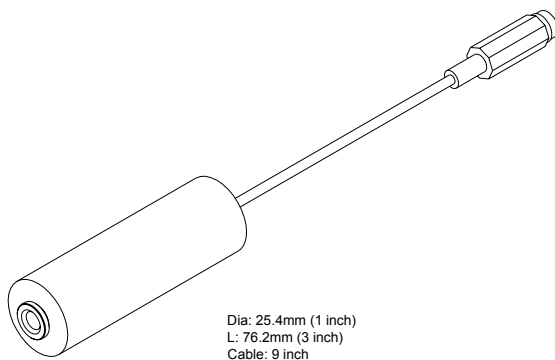

Power Supply

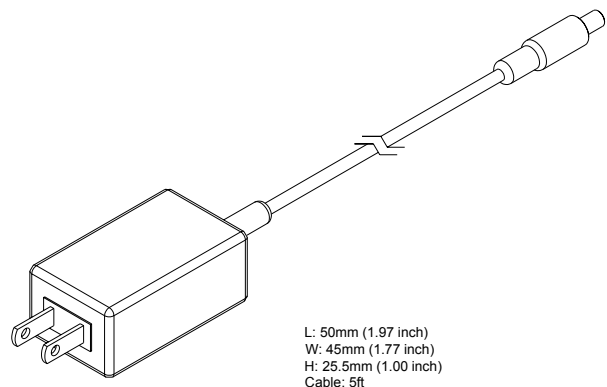

www.gmp.ch

Typical Characteristics of TEC Blue Laser System

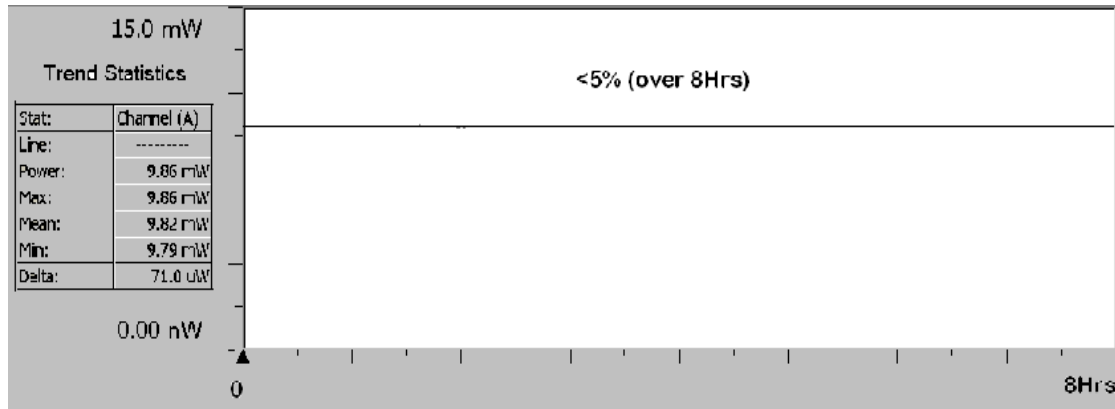

Power Stability

Order Information

Power	Part No.*	Classification
1 mW	TECBL- 1G – 473	Class II**
5 mW	TECBL- 5G - 473	Class IIIa**
10 mW	TECBL-10G-473	Class IIIb**
15 mW	TECBL-15G-473	Class IIIb ***

* Custom power levels are available. TTL modulation options and circularization options can be added on.

**Complies with CDRH 21CFRH 1040.10

***Modules sold solely for use in OEM equipment, OEM is responsible for compliance with all safety regulations.



Operational Hazard-Semiconductor Laser Diode Module: This laser module emits radiation that is visible and harmful to human eye. When in use, do not look directly into the laser emitting aperture. Direct viewing of laser diode emission at close range may cause eye damage.
Limited Warranty: One year. No warranty coverage for disassembly, modifications or damage due to abuse or misapplication.

Rev.D March. 2009

www.gmp.ch