

Precision Motors for Motion Control

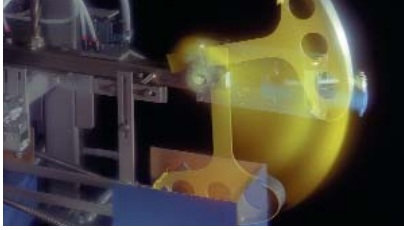

RNM CERAMIC SERVO MOTORS
by Nanomotion

A Johnson Electric Company



Based on the principles of ultrasonic standing waves in piezoelectricity, Nanomotion introduces its most advanced series of electronic motors, operating similarly to DC servo motors with the high resolution and dynamic performance of piezo actuators.

Nanomotion... A Breakthrough Technology

As the leading manufacturer of piezo-electric motors for precision motion control applications, Nanomotion's product line ranges from single element motors for actuation, to larger motors for driving typical stages. Nanomotion motors operate with no intrinsic magnetic fields and no moving parts. The motors provide unlimited travel in a compact package, with the ability to achieve unmatched precision for linear or rotary motion.

Nanomotion's motors have been successfully applied in diverse applications, using our standard housed motors for motion control positioning in industrial automation to simply applying a piezoelectric element embedded in consumer products. Regardless of the packaging, Nanomotion brings a unique drive solution to any motion requirement.

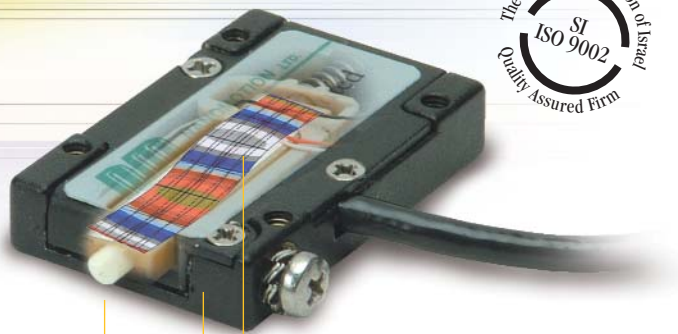

By pressing the ceramic finger tip against a ceramic strip a driving force is exerted on a linear or rotary stage, creating motion.

The simultaneous excitation of the longitudinal extension and transverse bending modes creating two dimensional acoustic waves resulting in a small elliptical path at the finger tip.

When the driving voltage is not applied, the compression of the finger tip to the ceramic maintains holding torque on the motion device. Unlike other braking devices, there is no position shift or hysteresis in the Nanomotion motor.

Table of Contents

Motor Technology	1	AB2	11
Semiconductor Applications	2	AB4	12
Biomedical Applications	4	AB5	13
HR Series	6	SB1291 Single Axis Drive	14
ST Motors	8	Ceramics	15
Amplifiers	9	MK Series	16
AB1A	10		

Nanomotion's unique motor technology makes it well suited to applications in:

- Semiconductor & Flat Panel Equipment
 - Normal Environments to Ultra-High Vacuum
- Fiber Optics Manufacturing and Dynamic Components
- Storage Media Manufacturing and Test Equipment
- Bio-Medical and Pharmaceutical Manufacturing
- Metrology
- General Automation



An exceptionally small operating package provides unlimited travel in a convenient and easy to mount package.



CE Compliant amplifier accepts +/- 10V from most all servo controls.

Plug-N-Play with simple connectorization and easy installation.

Built in spring cam allows for set up in less than 5 minutes, without the need for extensive alignment.

The operating nature of the finger tips provide unprecedented move and settle capability, along with built in braking.

Step resolutions better than 20 nanometers with a wide range of velocity from 1μ/sec to 250mm/sec.

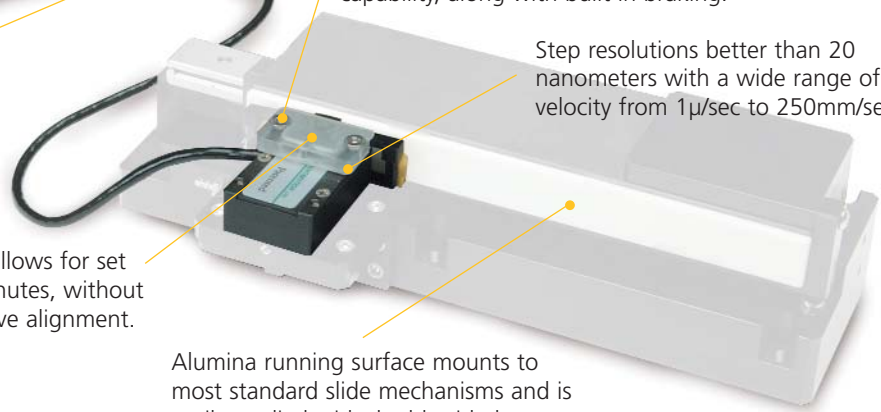

Alumina running surface mounts to most standard slide mechanisms and is easily applied with double sided tape.



Nanomotion motors are compatible with most standard positioning stages and servo controls. Nanomotion motors and amplifiers are compatible with the following stages and controls:

Stages

Aerotech | Anorad | Bayside | Daedal | Deltron | Dover Instruments
Industrial Devices | NEAT | Newport | Nutec | Schneeberger | Steinmeyer

Controls

Acroloop | ACS/Tech80 | Delta Tau | Galil | MEI
National Instruments | Nyquist | Parker Compumotor

Nanomotion Motors For The Semiconductor Market

Standard Motors:

- Clean Room Applications

Vacuum and Non-Magnetic Motors:

- Ebeam and Ion Beam Applications

Vacuum Compatible Motors:

- High Vacuum and UHV Applications

XYZT UHV Stage for Laser / Ion Beam Micromachining of Semicon Devices



This 4 axis motion system provides X/Y/Z and Theta motion for laser or Ion Beam machining of semiconductor chips or MEMs devices. The stage construction is UHV compatible to 10^{-10} Torr and has non-magnetic motors.

Each linear axis uses 50nm resolution linear encoders and the theta axis positions to 1 arc second. This stage can operate up to 200mm/sec.

Nanomotion manufactures a wide variety of vacuum and UHV motors for Semiconductor applications. Our vacuum motors, for environments up to 10^{-7} Torr are also available in non-magnetic configurations. These motors have no magnetic materials and no intrinsic magnetic field, and are ideal for E-Beam and Ion Beam applications, where magnetic motion can disturb the direction of the beam. Nanomtion's UHV motors are inherently non-magnetic and compatible to 10^{-10} Torr.

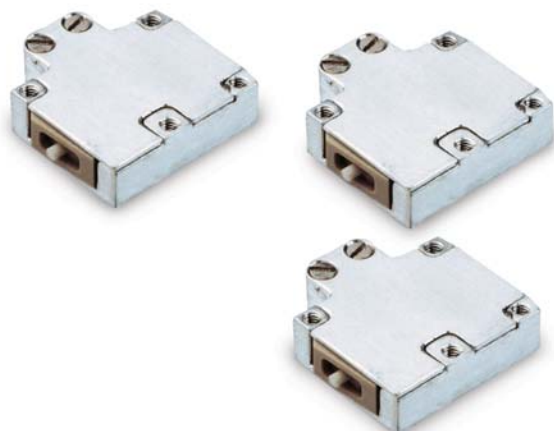
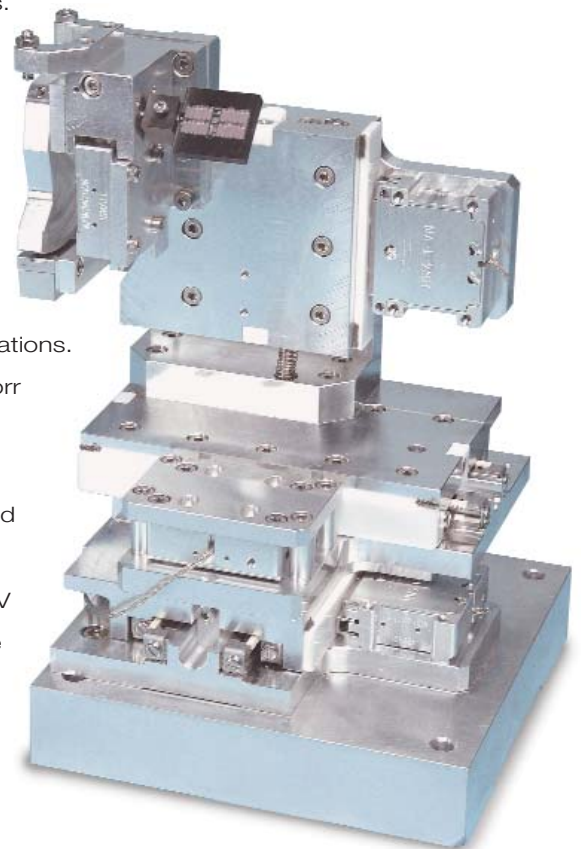

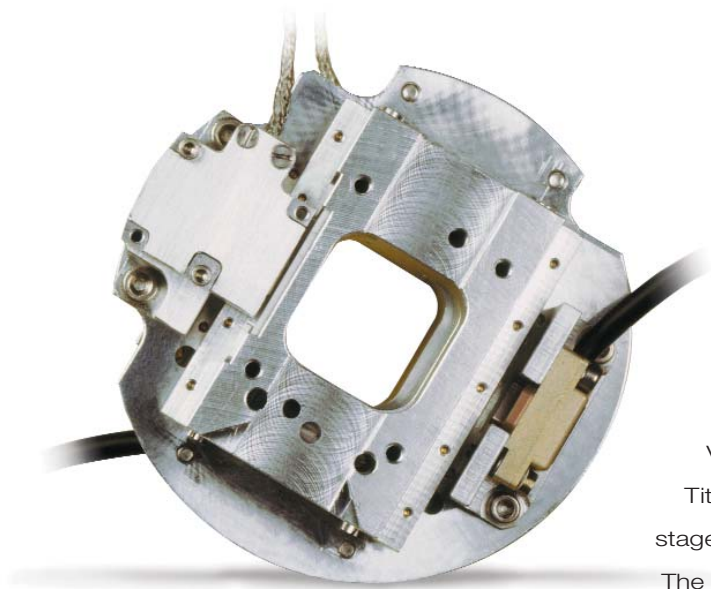

Vacuum / Non-Magnetic Stage

A dual axis stage providing 10mm travel in X and Y axes uses Nanomotion's ST motors, in a Ultra High Vacuum compatible and non-magnetic configuration. Titanium bearings provide for a completely non-magnetic stage construction.

The stages uses a 50nm resolution encoder and the entire assembly fits within a 75mm diameter.

Data Storage Certification Process



A single axis linear stage is used for track certification of a hard disk. The stage uses Nanomotion LS4 motors and a 100nm resolution linear encoders. (5nm optional)

Step sizes range from 1μ to 15μ in less than 10msec, settling to 200nm.

The stage operates in a class 100 clean room environment, on a 24/7 basis. Several hundred units have accumulated billions of cycles over the past several years.

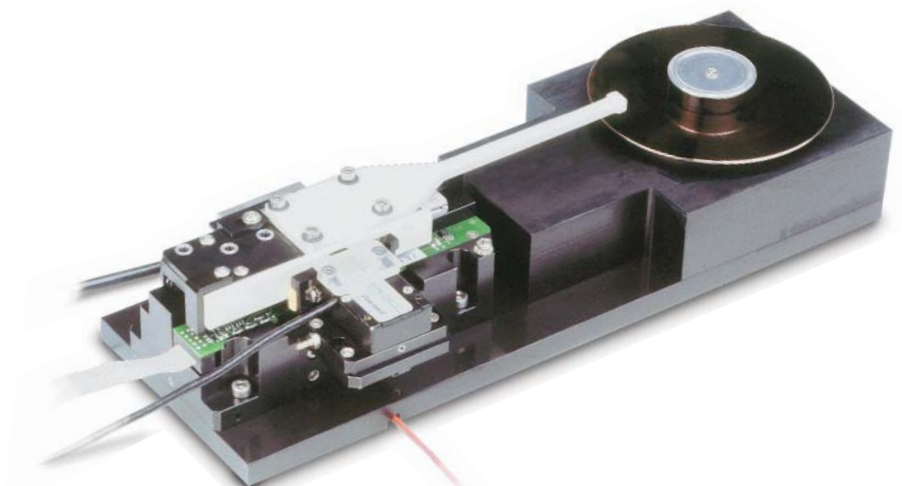

Nanomotion Motors For The BioMedical Market

Non-magnetic Motors:

- MRI Applications

Standard Motors:

- Microscope Stages
- Auto Focus Axes
- High Throughput Screening
- Clean Room Assembly Applications

Vacuum Motors:

- Laser & Mass Spectrometer Applications

Auto Focus & Scanning Stages for Cell Imaging and Virtual Microscopy

Nanomotion's auto focus stage is designed specifically for use in vertical orientation, with the dynamic performance to meet the demanding requirements of focusing on the fly. The stage uses a spring counterbalance to offset the load, and manage the demanding requirements of following Cell Terrain, during high speed imaging. Nanomotion's stages are also used extensively in the horizontal Step & Repeat or Scan on-the-fly, for cell imaging. The ability to provide high speed move & settle as well as smooth constant velocity offers the highest motion performance in the smallest footprint. While the stage technology can provide long travel, it can make focus moves in the range of 1 to 10 microns in 5 milliseconds, settling to 100nm.



Features

- Ceramic Servo Motor with Travel to 25mm
- High Resolution from 10nm to 100nm (1nm optional)
- Zero Backlash with Direct Drive
- High Speed Move & Settle for Focusing Operation
- Superior Position Stability and Zero Power Consumption at Rest
- Position Holding without Power Provides Optical Stability and Reduces Thermal Drift
- Easy Add-on Mounting to Standard Microscopes



Proteomics and Drug Development

High speed multi-axis systems use Nanomotion ceramic servo motors to provide the utmost in speed and performance, while maintaining an exceptionally small machine footprint.

Whether controlling the position of the dispensing head or actuating a series of syringes, Nanomotion provides compact, light weight motors that can operate in a lab environment.



Non-Magnetic Motors for MRI

MRI manipulators and robotics use Ceramic Servo Motors to control position while the MRI machine is on. The MRI creates an exceptionally high magnetic field preventing the use of

conventional motors. Nanomotion's motors are provided with NO magnetic materials and have no magnetic fields, eliminating the potential for artifacts on the display screen.

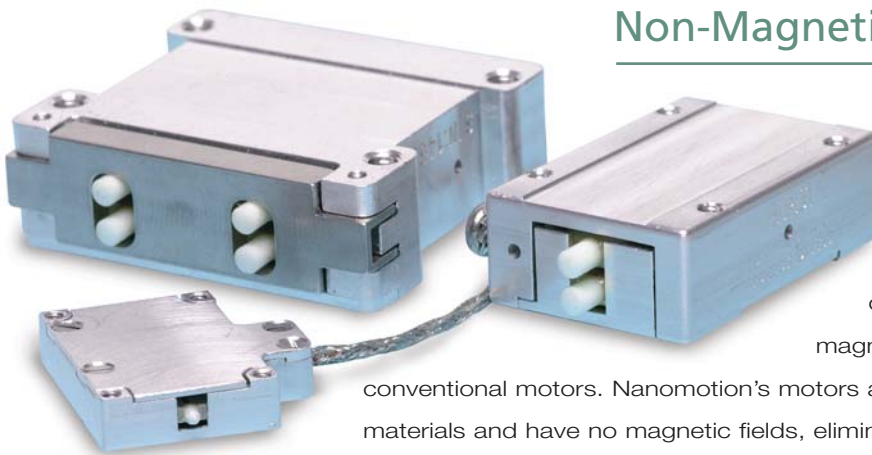

Nanomotion's HR Series motors range in a size from a single element (providing 0.4kg of force) to an eight element motor (providing 3.2kg of force). The HR series is capable of driving both linear and rotary stages. The HR series motors have a wide dynamic range of speed, from several microns per second to 250mm/sec and can easily mount to traditional low friction stages or other devices. The unique operating characteristics of the HR Series motors provide inherent braking and the ability to eliminate servo dither when in a static position.

Features

- Unlimited Travel
- Wide Dynamic Velocity Range
- From 1 μ /sec to 250mm/sec
- Excellent Move & Settle
- Step Resolutions to 10nm
- No Intrinsic Magnetic Field
- No External Magnetic Field Sensitivity (for Non-Magnetic Version)
- Vacuum Versions Available



Motor Performance Specifications

	Max Velocity (mm/sec)	Dynamic Stall Force (N)	Static Hold Force (N)	Static Stiffness (N/ μ)	Preload on Stage (N)	Kf Force Constant (N/Volt Commanded)
HR1	250	4	3.5	1	18	.75
HR2	250	8	7	1.8	36	1.5
HR4	250	16	14	2.8	72	3
HR8	250	32	28	3.8	144	6

Note: All motor performance data is based on using Nanomotion ceramic, motors and amplifiers.

Environmental

operating temperature:	0 to 50° C
storage:	-20°C to +70°C
humidity:	0 to 80%, non condensing
-V vacuum motors:	to 10 ⁻⁷ torr after bake out
-U ultra-high vacuum motors:	to 10 ⁻¹⁰ torr after bake out
max bake out temperature:	120°C for -V motors, 140°C for -U motors

Dimensions (European View)

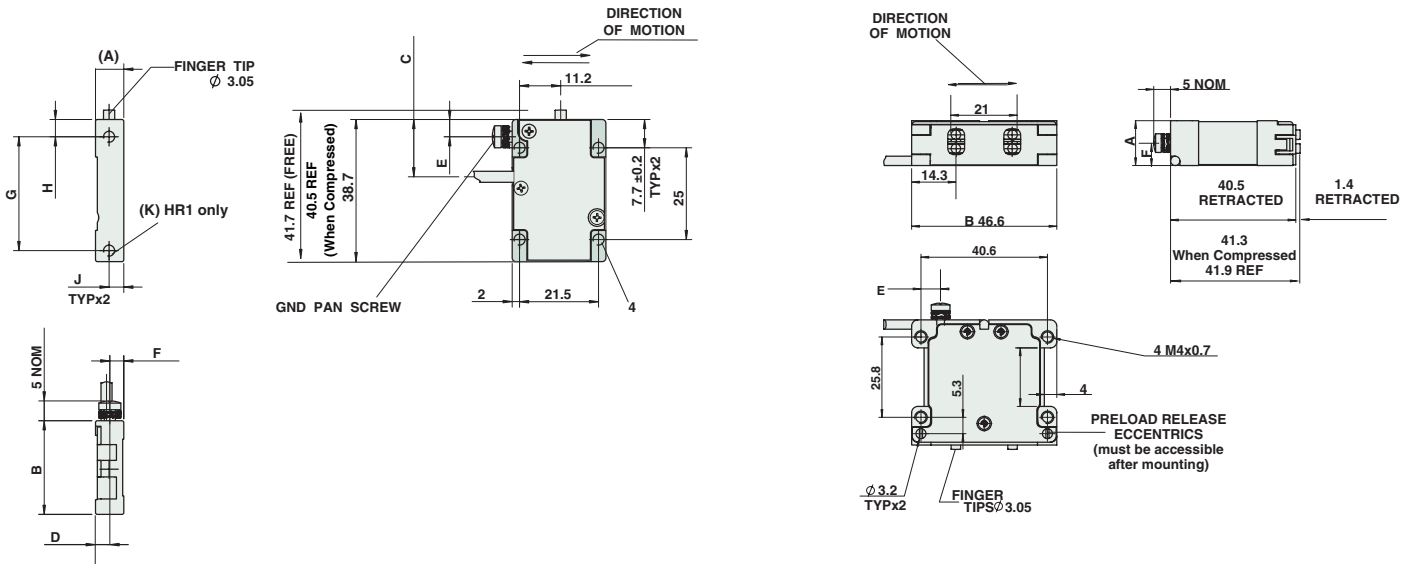

	A Motor Height	B Motor Width	C Cable Exit	D	E Gnd Screw	F Gnd Screw	G Side Mtg	H Side Mtg	J Side Mtg	K Screw Type	Motor Weight (Grams)
HR1-1-S	8	25.7	15.6	4.7	4.7	3.8	31	4.7	4	M3x0.5	30
HR1-1-V	8	25.7	15.6	4.7	4.7	3.8	31	4.7	4	M3x0.5	20
HR1-1-U	7.7	25.5	NA	NA	4	4	NA	NA	NA	NA	20
HR2-1-S	12.7	25.7	15.6	9.7	4.7	6	NA	NA	NA	NA	60
HR2-1-V	12.7	25.7	15.6	9.7	4.7	6	NA	NA	NA	NA	40
HR2-1-U	12.7	25.5	NA	NA	4	6	NA	NA	NA	NA	40
Terminal Mtg for U motors											
HR4-1-S	14.4	46.6	Bottom Back		9.3	7.2	NA	NA	NA	NA	73
HR4-1-V	14.4	46.6	Left or Right		9.3	7.2	NA	NA	NA	NA	73
HR4-1-U	14.9	46.6	NA	NA	NA	NA	NA	NA	6	NA	73
HR8-1-S	23.3	46.6	Bottom Back		9	12	NA	NA	NA	NA	170
HR8-1-V	23.3	46.6	Left or Right		9	12	NA	NA	NA	NA	120
HR8-1-U	23.8	46.6	NA	NA	NA	NA	NA	NA	12	NA	120

Note: All dimensions in mm

-S motors are Standard

-V motors are Vacuum Rated to 10^{-7} , Torr (use VN for Vacuum & Non-Magnetic)

-U motors are Vacuum Rated to 10^{-10} , Torr and are Non-Magnetic

-N motors are non-magnetic, for MRI environments

Envelope of Performance

curve	25°C		50°C		Vacuum	
	duty cycle	max. continuous operation time	duty cycle	max. continuous operation time	duty cycle	max. continuous operation time
a	100%	—	100%	—	100%	—
b	100%	—	100%	—	44%	184
c	100%	—	92%	137	26%	107
d	100%	—	62%	93	17%	72
e	78%	67 seconds	47%	70	13%	55
f	56%	62 seconds	33%	50	9%	39
g	50%	56 seconds	30%	45	8%	35

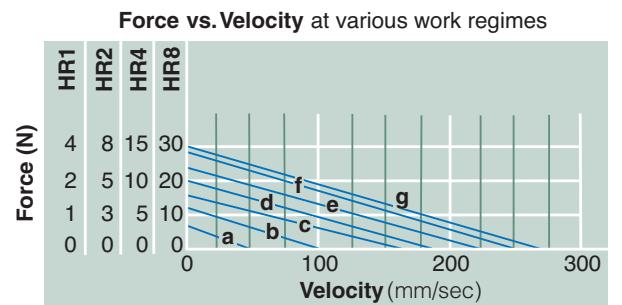

The ST Series Piezoelectric Motor is the smallest motor of its kind. The ST provides high resolution motion control for linear or rotary devices in a fraction of the space of traditional mechanisms. The ST is ideal for small stepping as well as continuous travel, with the ability to make step increments in the tens of nanometers and the ability to operate at speeds up to 250mm/sec.

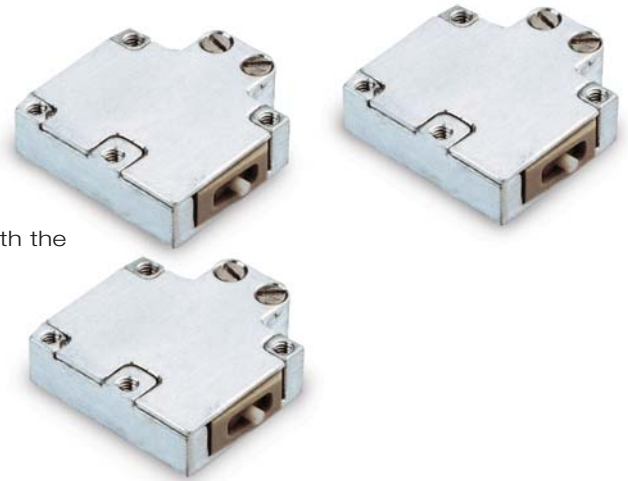

Features

- The Smallest Standard Piezo-Electric Package
- Unlimited Travel
- Wide Dynamic Velocity Range - from 1 μ m/sec to 250mm/sec
- Excellent Move & Settle
- Standard and Low Speed Version for High Resolution
- No Intrinsic Magnetic Field
- No External Magnetic Field Sensitivity

Dimensions (European View)

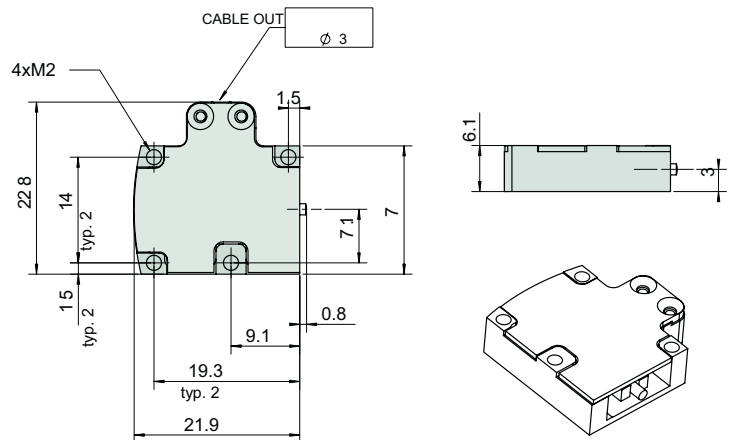

Motor Performance Specifications

	max velocity (mm/sec)	dynamic stall force (N)	static hold force (N)	static stiffness (N/ μ)	preload on stage (N)	Kf Force Constant (N/Volt Commanded)
ST-1-S	250	1.2	1	.15	8	.1
ST-1-V	250	1.2	1	.15	8	.1

Note: All Dimensions are in mm.

Environmental

operating Temperature: 0 to 50° C
 storage: -40°C to +70°C
 humidity: 0 to 80%, non condensing

Nanomotion offers 5 types of amplifiers to facilitate best performance of the motors.

AB1A- is the standard, heavy duty amplifier, widely used.

AB1A-3U- a board level AB1A amplifier card, in 3U format for motherboard interface.

AB2- facilitates additional ultra high resolution capabilities (UHR), down to 1 nanometer, using the unique DC mode.

AB4- a compact amplifier, powered by 12V supply.

AB5- the innovative linearized amplifier, yields excellent motion performance with any standard controller firmware.

	AB1A	AB1A-3U	AB2	AB4	AB5
unique functionality	nanomotion basic	board level 3U format	dc mode for ultra high resolution	compact amplifier package	linear response, operates with standard servo
supply voltage (vdc)	48	48	24	12	24
packaging	Panel mount box	Board level 3U format	Panel mount box	Small panel mount box	Panel mount box
max # of HR elements (1)	32	32	16	4	32
max motor cable length (3)	15	15	20	20	20
input signals (2)	±10vdc	±10vdc	±10vdc	±10vdc SPI Digital	±10vdc
modes of operation	Velocity Step Gate	Velocity Step Gate	Velocity Step Gate UHR position	Velocity Step Gate	Velocity Step Gate

	AB1A, AB1A-3U		AB2, AB5		AB4	
	regular cable	low capacitance cable	regular cable	low capacitance cable	regular cable	low capacitance cable
1HR element	0.5 to 5	0.5 to 8	0.5 to 10	0.5 to 20	0.5 to 10	0.5 to 20
2HR elements	0.5 to 5	0.5 to 8	0.5 to 10	0.5 to 20	0.5 to 10	0.5 to 20
4 HR elements	0.5 to 10	0.5 to 15	0.5 to 10	0.5 to 20	0.5 to 10	0.5 to 20
8 HR elements	0.5 to 10	0.5 to 15	0.5 to 10	0.5 to 20	NA	NA
16 HR elements	0.5 to 10	0.5 to 15	0.5 to 10	0.5 to 20	NA	NA
32 HR elements	0.5 to 10	0.5 to 15	0.5 to 10 (AB5)	0.5 to 20 (AB5)	NA	NA
1 ST element	3	3	NA	0.5 to 10	NA	0.5 to 10m
2 LS elements	0.5 to 5	NA	NA	NA	NA	NA
4 LS elements	0.5 to 5	NA	NA	NA	NA	NA
8 LS elements	0.5 to 5	NA	NA	NA	NA	NA

The AB1A amplifier is a single axis digital driver that can run one or multiple Nanomotion motors in parallel. While operating in a closed loop servo system, the driver works as a velocity amplifier, receiving a +/- 10 volt analog command from the controller. The controller signal translates into AC voltage, at 39.6 kHz to run the motor. In an open loop mode the amplifier can receive a signal from an external joystick, providing motion in a continuous or stepping mode.



Features

- Digital Drive Handles Up to 32 Elements
- Available in Eurocard 3µ Format
- +/- 10V Input from Servo Control
- Joystick Input for Open Loop Operation
- 2 Optically Isolated Limits
- Card Interface is 48 Pin 3 Row Connector

Amplifier Specifications

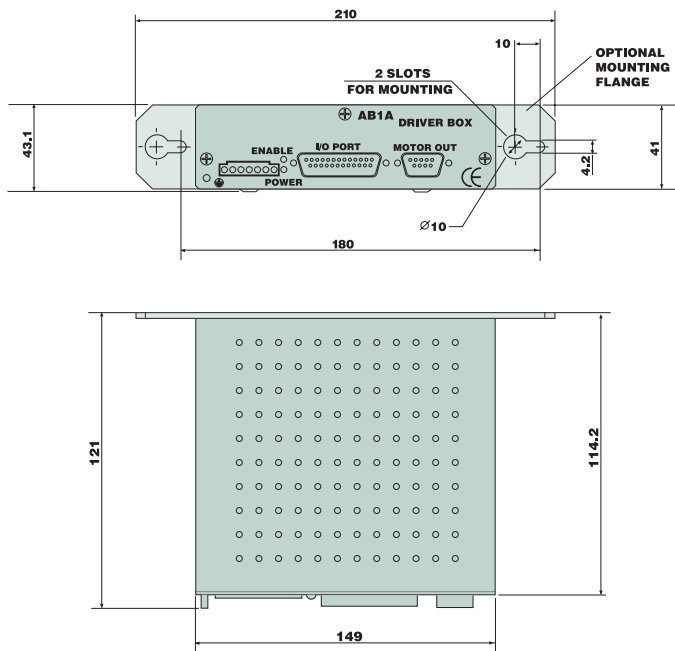

driving capability: up to 32 elements
(4 HR8 motors)

Analog Control Input

input voltage range: +/-10V
input impedance: 10 KΩ
input low pass filter: 2.7 KHz
input sampling resolution: 10 bits

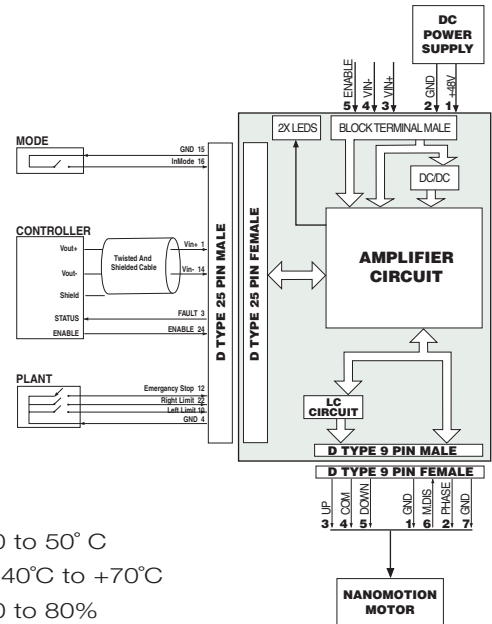

Environmental

operating temperature:
storage temperature:
humidity:

0 to 50° C
-40° C to +70° C
0 to 80%

Electrical

power input:
max motor output:
power consumption w/o load:
power consumption with max load:

+48Vdc±5%
270 to 280Vrms
+48Vdc/0.125A
+48Vdc/6.5Amax

The AB2 amplifier combines the normal Velocity mode of the AB1A amplifier, for servo operation, with the DC mode, for Ultra-High resolution positioning. The DC mode treats the motor as a traditional piezo actuator, providing the ability to make discrete moves at the 1 nanometer level.

The DC mode uses the same $\pm 10\text{V}$ analog signal from the controller output and translates it to a ± 300 nanometer position move capability, with 1 nanometer resolution. This function can be operated in an open loop or closed loop manner. The switching between the Velocity mode and DC mode is done seamlessly through a discrete input signal.



Features

- Ultra High Resolution Capability using DC Mode
- Digital Drive Handles 16 HR Motor Elements
- Requires 24Vdc Supply Input
- Cable Length up to 20m
- Over Current and Over Voltage Protection

Environmental

operating temperature:	0 to 50° C
storage:	-40°C to +70°C
humidity:	up to 80%, non condensing

Electrical

power supply input:	+24 Vdc $\pm 5\%$ (stabilized)
max motor output voltage:	280 Vrms
power consumption without load:	+24 Vdc/200 mA
power consumption with max load:	+24 Vdc/5A

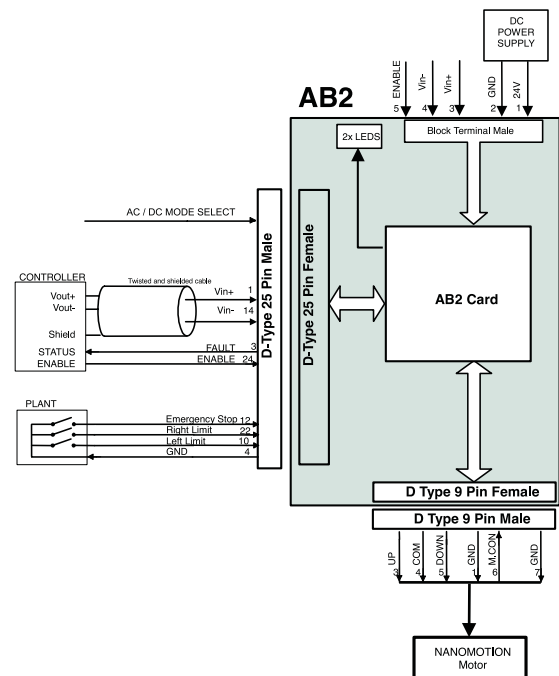
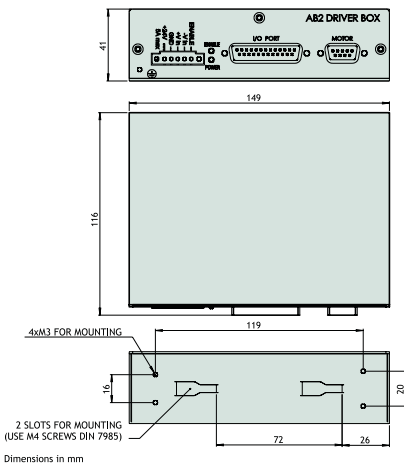

The AB4 amplifier offers the same performance as the AB1A, in a reduced package. The AB4 operates off of 12Vdc supply input and can drive up to 4 HR motor elements total, either (1) 4 element HR motor, or multiple HR motors totaling 4 elements.

The AB4 is the smallest standard motor amplifier and is provided with a 26-pin rear connector (26 pin, two row header). This connector provides access to all functionality (motor, power inputs, limits, and I/O functions), making it easy to integrate. Additional motor and power inputs are available with standard connections on the front.



Features

- Exceptionally compact mounting
- 12Vdc supply input
- Drives up to 4 HR motor elements
- Cable length up to 20m
- Over current and over voltage protection

Environmental

operating temperature: 0 to 50° C
 storage: -40°C to +70°C
 humidity: up to to 80%, non condensing

Electrical

power supply input: +12 Vdc \pm 5% (stabilized)
 max motor output voltage: 280 Vrms
 power consumption without load: +12 Vdc/300 mA
 power consumption with max load: +12 Vdc/3.5A

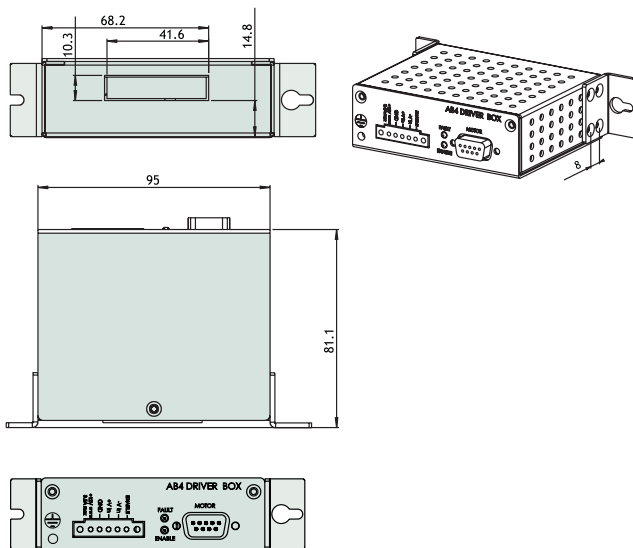

Dimensions in mm

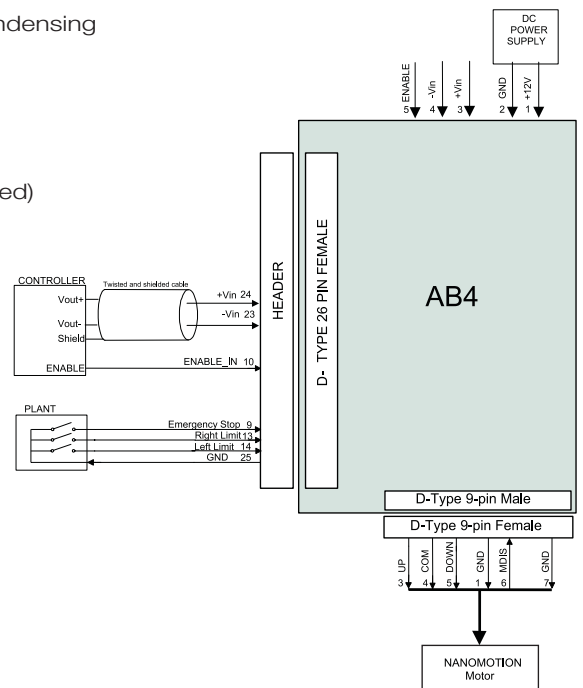

The AB5 amplifier revolutionizes the driving concept for Nanomotion ceramic servo motors, enabling a frictionless and smooth motion throughout the entire velocity range. At stop the inherent brake is activated, maintaining the many advantages of brake at power off. Consequently the control scheme is simplified, facilitating the use of any low cost servo controller to achieve outstanding performance.

As a result the whole range of controllers in the market place can be used with Nanomotion motors, as well as generic control algorithms. No custom algorithm is needed to be used with Nanomotion motors.

In addition, exceptional control performance is achieved at servo systems, showing robust performance at various working conditions.

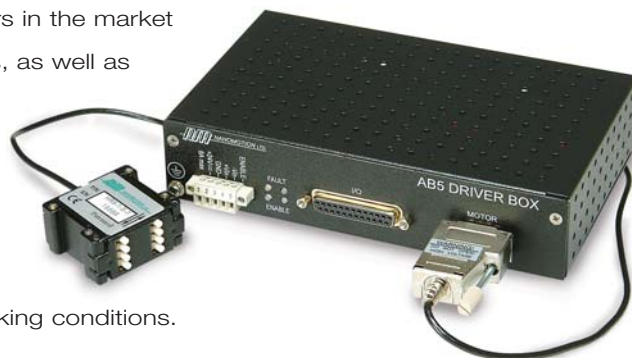

Features

- Compatible with any Servo Controller
- Linear Velocity Response at Full Command Range
- Brake On or Brake Off Upon Command
- Drives Up to 32 HR Motor Elements
- 24 Vdc Supply Input

Motor Performance Specifications

driving capability: up to 32 HR motor elements

Analog Control Input

input voltage range: $\pm 10V$
 input impedance: $10K\Omega$
 input low pass filter: 2.7 KHz
 input sampling resolution: 10 bits + direction

Environmental

operating temperature: 0 to 50° C
 storage: -40°C to +70°C
 humidity: up to 80%, non condensing

Electrical

power input: +24 Vdc $\pm 5\%$ (stabilized)
 power consumption without load: 24 Vdc/200 mA
 power consumption with max load: 24 Vdc/10A

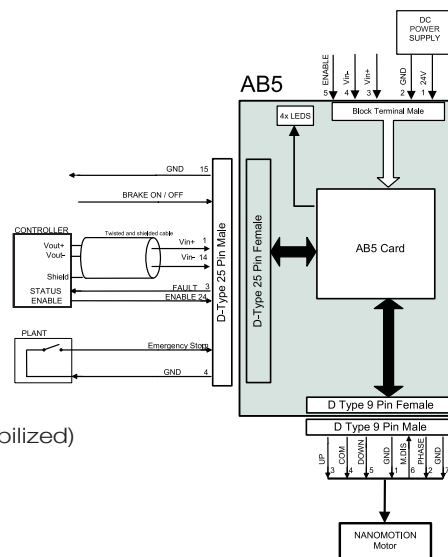
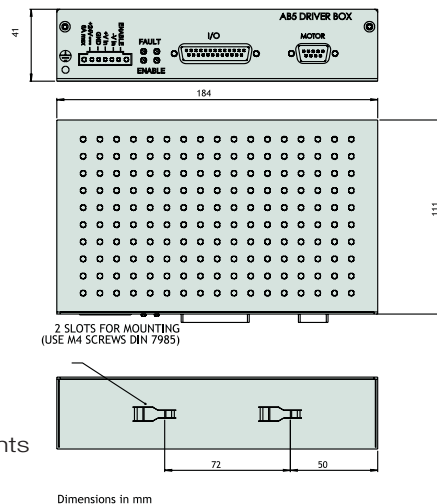

The SB1291 NM combines a single axis AB1A amplifier combined with a single axis, high performance, digital servo control card. This offers complete stand alone operation in a compact package with a high performance controller that is easy to use. The SB1291 NM comes complete with user interface software for the ease of application development and the ability to store preset programs.



Features

- Digital control with velocity and position loop sampling at 20kHz sampling rate
- Programmable operation for motion in position, velocity, manual joystick, and Master-Slave modes
- RS232 communication interface
- Comprehensive C Libraries for DOS and most Windows configurations
- Drive control can be provided with AB2 for nanometer positioning

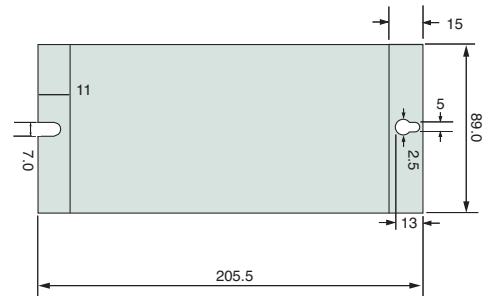

Dimensions & Specifications

communication:	RS232. Baud Rate up to 57600
encoder:	Two channel, +5VDC TTL compatible, 4MHz max, optically isolated
analog input:	1 input $\pm 10V$, 12 bit resolution
safety input:	End of travel limits & E Stop, optically isolated
inputs/outputs:	(8) optically isolated inputs 5 or 24V (8) optically isolated outputs 5 or 24V 50mamp per output
electrical input:	48Vdc $\pm 5\%$

Nanomotion supplies ceramic drive strips for all motor types. Standard strips, rings and disks are available in a wide variety of shapes and sizes. Nanomotion can also provide custom drive strips for different application requirements.

The ceramic drive is critical to the motor's performance. All specifications are based on using Nanomotion's ceramic. Nanomotion's ceramic comes standard with double sided tape for easy mounting. The Motor User Manual outlines the proper mounting procedures.



New: **CCS Ceramic Coated Steel Drive Strips**
Single piece lengths up to 4 meters. CCS strips can be provided in shorter lengths and can be easily cut for any in between lengths.

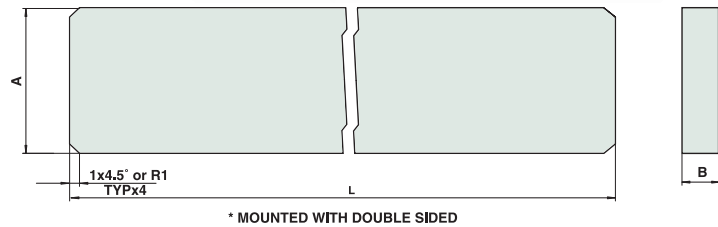

Strips

for use with		a	b	standard lengths**			
CS-10-1.5-200	ST, HR1	10	1.5	200	-	-	-
CS-10-3-XXX***	HR1, HR2, HR4	10	2.7	200	250	300	350
CS-20-3-XXX	HR8	20	2.7	200	250	300	350
CS-25-3-XXX*	HR8	25	2.7	200	250	300	350
CCS-20-5-XXX	HR1, HR2, HR4, HR8	20	4.6	500	1000	1500	2000

Note: All dimensions are in mm

- Note:**
- ** For special lengths, consult factory for pricing and availability
 - *** The XXX represents the required length of the ceramic strip; 50, 100, and 150mm are available as standard.
 - **** All ceramics are provided with double sided tape. Please specify in your order form if otherwise required.

Rings & Disks

motor preload		od	id	thickness
rings				
CR-12-9-5-X	a = axial, r = radial, ra = radial axial	12	9	5
CR-40-32-10-X*	a = axial, r = radial, ra = radial axial	40	32	10
CR-60-40-10-X	a = axial, r = radial, ra = radial axial	60	40	10
CR-100-80-10-X	a = axial, r = radial, ra = radial axial	100	80	10

Note: * The X represents the motor preload required for the ceramic ring, a = axial, r = radial, ra = radial axial

disks				
CD-146-114-1.5	axial	146	114	1.5
CD-192-60-5	axial	192	60	5
CD-192-150-5	axial	192	150	5

Nanomotion manufactures many other ring and disk sizes. Please contact us for non-standard sizes.

Motion Axis Kits

Nanomotion is in a unique position to provide complete single and multi-axis solutions utilizing its patented ceramic servo motor technology. The Motion Axis Kits leverages the advantage of the highest force per motor size focusing on assemblies that are smaller than typical linear stages, optimizing the performance of the motor.

The MK series consists of a family of standard crossed roller stages as well as complete custom designed motion platform to meet the most demanding motion control performance levels.



Features

- A wide range of motor sizes, from the ST motor (1.3N force) to the HR8 motor (40N force)
- .1 μ resolution linear encoders, with options from 10nm to 1 μ
- Compact crossed roller slides with a robust side motor mounting
- Travels up to 200mm standard, custom to 400mm
- Maximum velocity up to 250mm/sec
- Configurations for open loop, closed loop, or with a complete stand alone controller

The MK Series is offered in:

Open loop configurations: This consists of a linear slide with a motor, amplifier, power supply, and joystick. This is ideal for use where an operator is manually controlling position visually.

Closed loop configurations: This consists of a linear slide with a motor, linear encoder, amplifier, and power supply. This configuration is well suited for use with any servo control that can provide the amplifier with ± 10 Vdc to control the motor.

Servo configurations: This consists of a linear slide with a motor, linear encoder and a stand-alone drive & servo controller, and power supply that is fully programmable via RS232.

Unique Motion Solutions based on MK Series Motion Axis Kits

This miniature MK Series is available in open loop (shown here) or closed loop configurations, utilizing Nanomotion's ST motor and a 15mm wide slide assembly.

The ST motor will drive this stage with up to 1.3N force with a maximum velocity of 250mm/sec and completely unlimited travel.

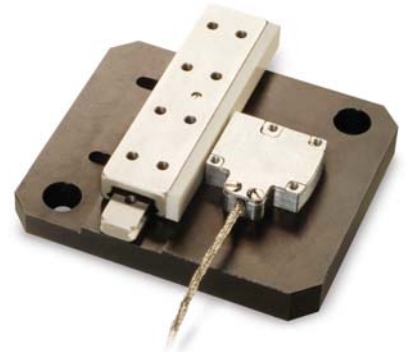

This long travel, closed loop actuator is easily configured for motion up to 4 meters in length.

The assembly consists of a profile linear rail with recirculating ball bearings mounted to an aluminum extrusion. A linear tape scale encoder is used for position feedback and the stage is driven with an HR8 motor providing 40N of force.

This assembly utilizes Nanomotion's new CCS, ceramic coated steel drive strip which is designed for long travel applications.



A four axis vacuum rated assembly, providing motion in X/Y/Z and Theta orientations, used for laser etching.

The assembly is vacuum rated to 10^{-7} Torr and uses non-magnet motors. The Z axis uses a spring counter balance to offset the vertical load and all stainless steel crossed roller axes use an anti-migration device in the bearing structure. This assembly provides 40mm travel in X & Y axes, 25mm travel in Z and up to 90 degrees in Theta.

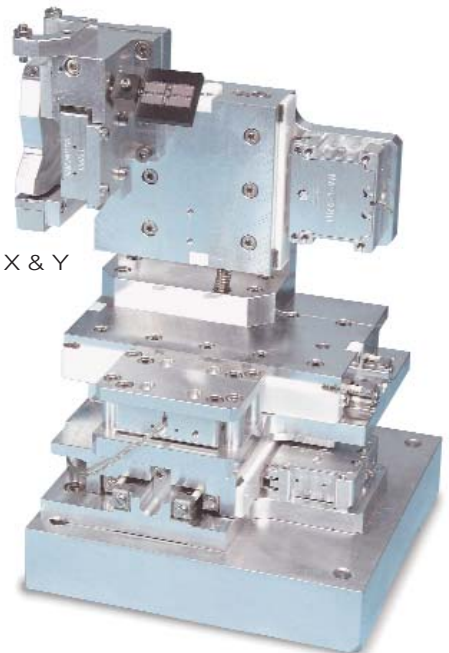



A Johnson Electric Company

Nanomotion Ltd. Worldwide Headquarters

P.O. Box 623
Yokneam, Israel 20692
t: (972)4-9590862
f: (972)4-9590995
e: nano@nanomotion.com

Nanomotion Inc. U.S. Headquarters

1 Comac Loop, Suite 14B2
Ronkonkoma, New York 11779
t: (800) 821-6266
t: (631) 585-3000
f: (631) 585-1947
e: nanoUS@nanomotion.com

Nanomotion Inc. West Coast Office

2570 North First St. Suite 200
San Jose, CA 95131
t: (408) 273-4562
f: (408) 273-4662
e: nanoUS@nanomotion.com